

SHARP SERVICE MANUAL

CODE: 00ZAR162//A1E

DIGITAL COPIER

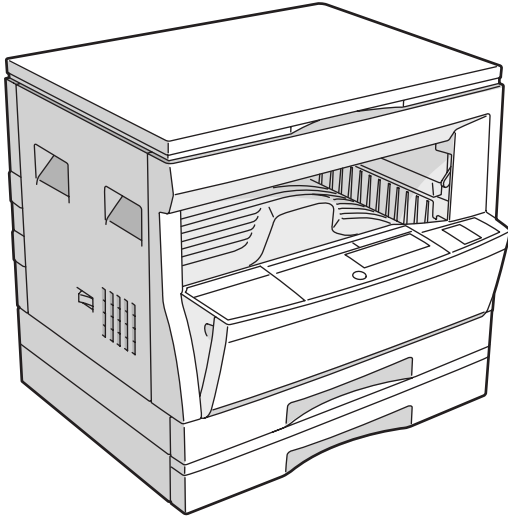

AR-162

AR-163

AR-201

AR-206

AR-207

MODEL AR-F201

CONTENTS

[1] GENERAL	1-1
[2] SPECIFICATIONS	2-1
[3] CONSUMABLE PARTS	3-1
[4] EXTERNAL VIEWS AND INTERNAL STRUCTURES	4-1
[5] UNPACKING AND INSTALLATION	5-1
[6] ADJUSTMENTS	6-1
[7] SIMULATIONS	7-1
[8] USER PROGRAMS	8-1
[9] TROUBLE CODE LIST	9-1
[10] MAINTENANCE	10-1
[11] DISASSEMBLY AND ASSEMBLY	11-1
[12] FLASH ROM VERSION UP PROCEDURE	12-1
[13] ELECTRICAL SECTION	13-1

Parts marked with "  " are important for maintaining the safety of the set. Be sure to replace these parts with specified ones for maintaining the safety and performance of the set.

CAUTION

This product is a class 1 laser product that complies with 21CFR 1040.10 and 1040.11 of the CDRH standard and IEC825. This means that this machine does not produce hazardous laser radiation. The use of controls, adjustments or performance of procedures other than those specified herein may result in hazardous radiation exposure.

This laser radiation is not a danger to the skin, but when an exact focusing of the laser beam is achieved on the eye's retina, there is the danger of spot damage to the retina.

The following cautions must be observed to avoid exposure of the laser beam to your eyes at the time of servicing.

- 1) When a problem in the laser optical unit has occurred, the whole optical unit must be exchanged as a unit, not as individual parts.
- 2) Do not look into the machine with the main switch turned on after removing the developer unit, toner cartridge, and drum cartridge.
- 3) Do not look into the laser beam exposure slit of the laser optical unit with the connector connected when removing and installing the optical system.
- 4) The middle frame contains the safety interlock switch.
Do not defeat the safety interlock by inserting wedges or other items into the switch slot.

Warning!

This product is a class A product.

If it is operated in households, offices or similar surroundings, it can produce radio interferences at other appliances, so that the user has to take adequate countermeasures.

CLASS 1 LASER PRODUCT

LASER KLASSE 1

LUOKAN 1 LASERLAITE

KLASS 1 LASERAPPARAT

VAROITUS!

LAITTEEN KÄYTTÄMINEN MUULLA KUIN TÄSSÄ KÄYTTÖOHJEESSA MAINITULLA TAVALLA SAATTAA ALTISTAA KÄYTTÄJÄN TURVALLISUUSLUOKAN 1 YLITTÄVÄLLE NÄKYMÄTTÖMÄLLE LASERSÄTEILYLLE.

VARNING

OM APPARATEN ANVÄNDS PÅ ANNAT SÄTT ÄN I DENNA BRUKSANVISNING SPECIFICERATS, KAN ANVÄNDAREN UTSÄTTAS FÖR OSYNLIG LASERSTRÅLNING, SOM ÖVERSKRIDER GRÄNSEN FÖR LASERKLASS 1.

CAUTION

INVISIBLE LASER RADIATION,
WHEN OPEN AND INTERLOCKS DEFEATED. AVOID
EXPOSURE TO BEAM.

VORSICHT

UNSIHTBARE LASERSTRÄHLUNG,
WENN ABDECKUNG GEÖFFNET UND
SICHERHEITSVERRIEGELUNG ÜBERBRÜCKT. NICHT
DEM STRAHL AUSSETZEN.

VARO!

AVATTAESSA JA SUOJALUKITUS OHITETTAESSA OLET
ALTTIINA NÄKYMÄTTÖMÄLLE LASERSÄTEILYLLE ÄLÄ
KATSO SÄTEESEEN.

ADVARSEL

USYNLIG LASERSTRÅLNING VED ÅBNING, NÅR
SIKKERHEDSBRYDERE ER UDE AF
FUNKTION. UNDGÅ UDSÆTTELSE FOR
STRÅLNING.

VARNING!

OSYNLIG LASERSTRÅLNING NÅR DENNA DEL ÄR
ÖPPNAD OCH SPÅRREN ÄR URKOPPLAD. BETRakta EJ
STRÅLEN. – STRÅLEN ÄR FARLIG.

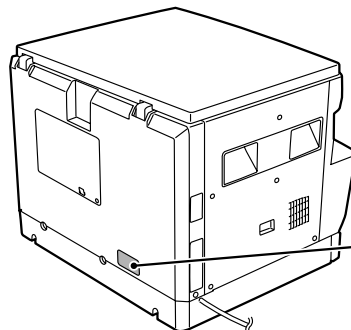
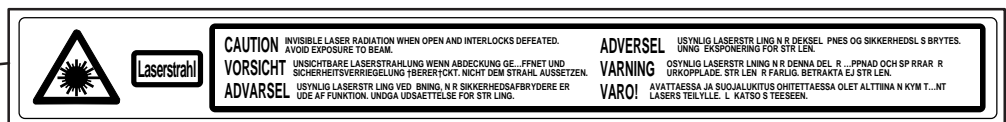
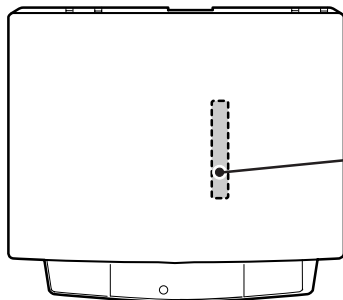

LASER WAVE – LENGTH : 795 ± 15 mm

Pulse times : 0.481 ms/6 mm

Out put power : 5 mW

Disconnect the AC cord before servicing the unit.

CONTENTS

[1] GENERAL	1-1	[8] USER PROGRAMS	8-1
1. Note for servicing	1-1	1. List of user programs	8-1
[2] SPECIFICATIONS	2-1	2. Setting the user programs	8-1
1. Copy mode	2-1	[9] TROUBLE CODE LIST	9-1
[3] CONSUMABLE PARTS	3-1	1. Trouble code list	9-1
1. Supply system table	3-1	2. Details of trouble codes	9-1
2. Environment conditions	3-3	[10] MAINTENANCE	10-1
3. Production number identification	3-3	1. Maintenance table	10-1
4. Consumable parts recycling procedure	3-4	[11] DISASSEMBLY AND ASSEMBLY	11-1
[4] EXTERNAL VIEWS AND INTERNAL STRUCTURES	4-1	1. High voltage section/Duplex transport section ..	11-1
1. Appearance	4-1	2. Optical section	11-2
2. Internal	4-1	3. Fusing section	11-3
3. Operation Section	4-2	4. Paper exit section	11-5
4. Motor, solenoid, clutch	4-3	5. MCU	11-7
5. Sensor, switch	4-4	6. Optical frame unit	11-7
6. PWB unit	4-5	7. LSU	11-7
7. Cross sectional view	4-6	8. Tray paper feed section/ Paper transport section	11-8
[5] UNPACKING AND INSTALLATION	5-1	9. Manual multi paper feed section	11-9
1. Installing conditions	5-1	10. Power section	11-11
2. Removal of protective material and fixing screw	5-1	11. Developing section	11-12
3. Installation of developing cartridge	5-1	12. Process section	11-13
4. Removal and storage of fixing screw	5-2	[12] FLASH ROM VERSION UP PROCEDURE ..	12-1
5. Changing the copy paper size in the tray	5-3	1. MCU/E-SORT	12-1
[6] ADJUSTMENTS	6-1	2. PRINTER CONTROL PWB FIRMWARE VERSION UP	12-1
1. Adjustment item list	6-1	[13] ELECTRICAL SECTION	13-1
2. Copier adjustment	6-1	1. BLOCK DIAGRAM	13-1
[7] SIMULATIONS	7-1	2. ACTUAL WIRING DIAGRAM	13-2
1. Entering the simulation mode	7-1		
2. Cancelling the simulation mode	7-1		
3. List of simulations	7-1		
4. Contents of simulations	7-2		

[1] GENERAL

The AR-207 is a revised model of the AR-206 with the E-sort PWB and RSPF. For the E-sort PWB, refer to the service manual of the AR-EB3, and for the RSPF the service manual of the AR-RP1.

The AR-F201 is a revised model of the AR-201 with the FAX function. For the FAX section, refer to the AR-FX2 Service Manual, for the SPF the AR-SP2 Service Manual, and for the LCD panel the AR-PA1 Service Manual.

1. Note for servicing

Pictogram

This Service Manual uses some pictographs to assure safe operation.

Please understand the meanings of pictographs before servicing.

 **WARNING:** If this WARNING is ignored, serious injury or death could occur.

 **CAUTION:** If this CAUTION is ignored, an injury or damage to property could occur.

A. Warning for servicing

- 1) Be sure to use the rated voltage and the rated current specified on the rating label. Avoid complex wiring. It may cause a fire.
- 2) If smoke or abnormal smell occurs, stop servicing and disconnect the power plug. It may cause a fire.
- 3) Be sure to set the ground wire. If not, a fire or an electric shock may occur. The ground wire is required also for protecting the machine from lightning.
- 4) If the ground wire is connected to the following places, an explosion, fire, or electric shock could result. Be sure to avoid it.
 - Gas pipe
 - Lightning conductor
 - Water pipe (which is not approved as a ground pipe by the authority), water faucet
 - Ground wire for telephone
- 5) Do not cut or modify the power cord.
Do not put a weight on the power cord. Do not bend or pull it extremely. These actions could result in fire.
- 6) Keep the power cord away from a heater or a heated material. Remove dust from the power plug. If the power plug with dust on it should be inserted into the power outlet, it may cause a fire or an electric shock.
- 7) Do not put a container with water in it, or a small piece of metal on the machine. If water or a metal piece would drop inside the machine, it could cause a fire or an electric shock.
- 8) When touching the power plug, inserting/removing the telephone line connector, or operating the machine, be sure to dry and clean your hands to prevent against an electric shock.

B. Cautions for servicing

- 1) Except when in a communication test or other unavoidable situations, be sure to disconnect the power plug, the printer cable, the network cable, and the telephone line from the machine when servicing.
- 2) There are several heated areas in the machine, which can cause a burn if touched. Use great care when servicing.
- 3) There are some high voltage sections in the machine, which may cause an electric shock. Use great care when servicing.
- 4) Do not disassemble the laser unit. Do not insert a screwdriver or other reflecting material in the laser path. Reflected laser beam can cause injury to your eyes.
- 5) When servicing with the machine operating, use great care not get caught by chain, belt, gear, of other driving sections.

- 6) Do not leave the machine with the cabinet removed. If any other person than the serviceman would touch the machine, he or she could be injured by fire or electric shock.
- 7) Be careful to protect your eyes from toner, developing agent, and ink. Be careful not to inhale them.
If toner, developing agent, or ink should enter your eyes, wash them with water and consult a doctor if necessary.
- 8) There are some sharp edges in the machine. Be careful not to injure your fingers when servicing.
- 9) Do not put toner or waste toner or a container with toner or waste toner from the copier into a fire.
- 10) When replacing the lithium battery attached to the PWB, be sure to use the one specified. If the specification of the battery is not the one specified, the battery may explode causing a breakdown or malfunction of the machine.
- 11) When carrying a part of the unit with a PWB or an electronic part, be sure to put it in an anti-static-electricity bag. Otherwise a breakdown or malfunction may occur.

C. Note for installation place

The machine performances depend on the environmental conditions of the installation areas. Avoid installation in the following areas:

- 1) Avoid high temperature, high humidity, low temperature, low humidity.
Avoid areas subject to a rapid change in temperature and humidity.
If installed in such a place, paper may be dampened and condensation may form inside the machine, causing paper jam or dirty copy. For use and storage of the machine, refer to the specifications described below.
- 2) Avoid areas with excessive vibration. It may cause a breakdown of the machine.
- 3) Avoid a poorly ventilated area.
This machine uses the static electricity copy process, ozone is generated in the machine. The quantity of ozone generated is designed to a harmless level. If, however, the machine is used continuously in a poorly ventilated place, there may be a smell of ozone. Therefore install the machine in a well-ventilated area.
- 4) Avoid area with direct sunlight.
Direct sunlight may deform plastic parts or discolor and spoil toner, causing dirty copy or a breakdown of the machine.
- 5) Avoid area with ammonium or organic gases.
This machine which uses an organic photoconductor (OPC) drum, the drum may be damaged by ammonium or organic gases.
Avoid installation near a diazo type copier. It may cause dirty copy or a breakdown of the machine.
- 6) Avoid a dusty area.
If dust enters the machine, it may cause dirty copy or a breakdown of the machine.
- 7) Avoid installation near a wall.
Some machines have an exhaust and intake vent. If the exhaust or intake is obstructed, it may cause dirty copy or a breakdown of the machine.
- 8) Avoid installation on an unstable surface. The machine could drop or tip over causing an injury or a breakdown of the machine. If the paper feed desk or an option desk is available, it is advisable to use it. When using an option desk, be sure to fix the adjusters on the floor and lock the casters.

[2] SPECIFICATIONS

1. Copy mode

A. Type

Type	Desk-top
------	----------

B. Machine composition

AR-162	16-CPM standard model
AR-163	16-CPM standard model (with shifter)
AR-201	20-CPM standard model (with shifter)
AR-206	20-CPM duplex model (with shifter)
AR-207	20-CPM duplex model (with shifter, R-SPF, E-sort)
AR-F201	20-CPM (with FAX, SPF)

(1) Option

Machine	Model	
250 sheets paper feed unit	AR-DE5	
250 sheets × 2 paper feed unit	AR-DE6	
SPF	AR-SP2	AR-F201 standard
RSPF	AR-RP1	AR-207 standard
Original cover	AR-VR1	
Electronic sorting kit	AR-EB3	AR-207 standard
Printer expansion kit	AR-PB8	
Facsimile extension kit	AR-FX2	AR-F201 standard
LCD panel kit (20 digits × 2 lines)	AR-PA1	AR-F201 standard
Job separator tray	AR-TR2	AR-F201 standard
PS2 expansion kit	AR-PS1	
Extension memory for FAX (2MB)	AR-MM5	
Extension memory for FAX (4MB)	AR-MM6	
Extension memory for FAX (8MB)	AR-MM7	

C. Copy speed

(1) Scan One Print many

AR-162	Not available (Available for AR-163 for North America, Australia, Asia)
AR-163	
AR-201/F201	Available
AR-206/207	

Condition: Copy speed in the normal copy from all the paper feed ports including the manual paper feed port.

(2) Continuous copy speed (Sheets/min)

a. AR-162/163

Paper size		Normal	Enlargement (200%)	Reduction (50%)
AB system	A3	9	9	9
	B4	10	10	10
	A4	16	16	14
	A4R	12	12	12
	B5	16	16	16
	B5R	14	14	14

Paper size		Normal	Enlargement (200%)	Reduction (50%)
Inch system	11" × 17"	9	9	9
	8.5" × 14"	10	10	10
	8.5" × 13"	11	11	11
	8.5" × 11"	16	16	14
	8.5" × 11"R	12	12	12
	8.5" × 5.5"	16	16	16

b. AR-201/206/207/F201

Paper size		Normal	Enlargement (200%)	Reduction (50%)
AB system	A3	11	11	11
	B4	12	12	12
	A4	20	20	20
	A4R	14	14	14
	B5	20	20	20
	B5R	16	16	16
Inch system	11" × 17"	10	10	10
	8.5" × 14"	12	12	12
	8.5" × 13"	12	12	12
	8.5" × 11"	20	20	20
	8.5" × 11"R	15	15	15
	8.5" × 5.5"	20	20	20

D. First copy time

(1) Basic speed

First copy time	7.2sec (A4, 8.5" × 11"/1st tray/with OC)
-----------------	--

E. Document

Max. document size	A3, 11" × 17"	
Document reference position	Left side center	
Detection (Platen)	AR-162	None
	AR-163	
	AR-201/F201	Available
	AR-206/207	
Detection size	A3, B4, A4, A4R, B5, B5R, A5 11" × 17", 8.5" × 14", 8.5" × 13", 8.5" × 11", 8.5" × 11"R, 8.5" × 5.5" (8.5" × 13" is detected by key input.)	

(1) SPF/R-SPF

Standard/Option	Option SPF; AR-SP2 (AR-F201 standard) RSPF; AR-RP1 (AR-206 only) (AR-207 standard)
Document load capacity	30 sheets (56 ~ 90g/m ² equivalent) (15 ~ 23.9 lbs.)
Document size (Max. ~ Min.)	A3 ~ A5 11" × 17" ~ 8.5" × 5.5" (8.5" × 5.5", duplex is inhibited.)
Document replacement speed	16 sheets/min (A4 × 8.5" × 11" normal copy)
Document set/Paper feed direction	Face up, Center reference, Paper feed from the top
Document weight	56 ~ 90g/m ² , 15 ~ 23.9 lbs
Document size detection	On the document feed tray
Document mixture	Copy mode: Not Available

F. Paper feed

Copy size (Max. ~ Min.)	(A3 ~ A6) 11" × 17" ~ 8.5" × 5.5"	
Paper feed system	AR-162	1 cassette + Multi manual paper feed
	AR-163	
	AR-201/F201	2 cassette + Multi manual paper feed
	AR-206/207	
Paper feed capacity	AR-162	50 × 1 (Paper feed tray) + 100 (Multi bypass feed tray)
	AR-163	
	AR-201/F201	250 × 2 (Paper feed tray) + 100 (Multi bypass feed tray)
	AR-206/207	
Remaining quantity detection	Cassette section	Empty detection available, size detection by key input
	Manual tray	Only empty detection available

(1) Paper feed section of the copier

Paper feed size	A3, B4, A4, A4R, B5, B5R, A5 11" × 17", 8.5" × 14", 8.5" × 13", 8.5" × 11", 8.5" × 11"R, 8.5" × 5.5" (For A5 and 8.5" × 5.5", only No. 1 tray available.)
Side front	Front
Paper feed capacity	250 sheets (56 ~ 80g/m ² equivalent) (15 ~ 21 lbs.)
Detection	Paper empty detection available, size detection (by key input)
Weight	56 ~ 80g/m ² (15 lbs. ~ 21 lbs.)
Special paper	Recycled paper

(2) Manual paper feed section

Paper feed size	A3 ~ A6, 11" × 17" ~ 8.5" × 5.5"
Paper feed capacity	100 sheets
Detection	Size detection not available, paper empty detection available
Weight	56 ~ 128g/m ² (15 ~ 34 lbs.)
Special paper	Recycled paper, OHP film, labels
Paper feed	Single except for recycled paper

(3) Option paper feed unit

	1-step paper feed unit	2-step paper feed unit
Model	AR-DE5	AR-DE6
Paper feed size	A3, B4, A4, A4R, B5, B5R 11" × 17", 8.5" × 14", 8.5" × 13", 8.5" × 11", 8.5" × 11"R	
Capacity (56 ~ 80g/m ²)	About 250 sheets × 1 step	About 250 sheets × 2 steps
Paper weight	56 ~ 80 g/m ² (15 ~ 21 lbs.)	
Moisture preserving heater	None	
Detection	Paper empty detection, size detection (by key input)	
Paper size setting	User setting (by key input)	
External dimensions (W × D × H)	590 × 471 × 88mm	590 × 471 × 173.5mm
Weight	About 5kg	About 10kg
Special paper	Recycled paper	
Power	Supplied from the machine	

G. Job speed

S-S (1st step)	100% (document replacement rate) (AR-162/163) 80% (document replacement rate) (AR-201/206/207/F201)
----------------	--

Condition: With SPF

H. Multi copy

Max. number of multi copy	99 sheets
---------------------------	-----------

I. Warmup time

Warmup time	Approx. 35 sec *
Pre-heat	Available

* May vary depending on the surrounding temperature.

J. Copy magnification ratio

Fixed magnification ratio	AB system: 50, 70, 81, 86, 100, 115, 122, 141, 200% Inch system: 50, 64, 77, 95, 100, 121, 129, 141, 200%
Zooming	50 ~ 200%
Independent zooming/vertical	Available (50 ~ 200%)
Independent zooming (horizontal)	Available (50 ~ 200%)

K. Print density

Density mode	Auto/Manual/Photo
No. of manual adjustment	5 steps (Manual/Photo)
Toner save mode	Set by the user program

L. Void width

Void area	Lead edge 1 ~ 4mm, rear edge 4mm or less (Duplex 4mm or less), both sides 4mm or less
Image loss	Max. 4mm in total of lead edge and rear edge, max. 4mm in total of right and left edges (Normal copy)

M. Auto duplex

Standard/Option	Standard provision (AR-206/207 only) (D → D/D → S enable only when RSPF is installed) Not available for AR-162/163/201/F201
-----------------	--

N. Paper exit/finishing

Paper exit section capacity	Face down 250 sheets	
Job separator	Job separator, option (AR-TR2) (AR-F201 standard)	
	Upper: FAX/Printer, Lower: Copier Upper: 100sheets, Lower 150sheets	
	Full detection	
	Available (Job separator upper step)	
Finishing	Electronic sort board: Option (AR-EB3) (AR-207 standard)	
Electronic sort capacity	A4 (8.5" × 11") standard document 60 sheets	
Offset function	AR-162	None
	AR-163	Available (by the shifter)
	AR-201/F201	
	AR-206/207	
Staple function	None	

(1) Electronic sort board (Option AR-207 standard)

Electronic sort	Sorting	60 sheets of A4 standard documents
	Grouping	60 sheets of A4 standard documents
Rotation copy	If there is paper of same size as the document, the image is rotated to copy even though the paper is set in the different direction from the document direction.	
2 in 1, 4 in 1	Copies of 2 pages or 4 pages are integrated into one surface. Divided by solid lines, (Selectable by the user program.)	
Edge erase	Images surrounding the document are erased when copying. (Adjustable in 0 ~ 20mm by the user program.)	
Center erase	The image at the center is erased when copying. (Adjustable in 0 ~ 20mm by the user program.)	
Margin shift	Binding margin is made at the left edge of the set documents.	

O. Additional functions

APS`	<input type="radio"/>	(APS not available by flowing in during use of SPF/RSPF)
AMS`	<input type="radio"/>	(AMS not available by flowing in during use of SPF/RSPF)
Duplex	<input type="radio"/> X	AR-206/207 only available
Document count	X	
Sorter	<input type="radio"/>	When the electronic sort board installed.
Independent zooming	<input type="radio"/>	Vertical/Horizontal: 50 ~ 200%
1 set 2 copy	<input type="radio"/>	Enlargement inhibited, inhibited during the use of SPF
Binding margin	<input type="radio"/>	Shift width 9mm
Edge erase	<input type="radio"/>	Width 5mm (Adjustable 0 ~ 20mm)
Black-white reversion	<input type="radio"/>	Whole surface only
2 in 1, 4 in 1	<input type="radio"/>	
Rotation copy	<input type="radio"/>	
Memory copy	<input type="radio"/> X	(AR-201/206/207/F201 and AR-163 for North America, Australia, Asia: Available)
Pre-heat function	<input type="radio"/>	Conditions set by the user program
Auto power shut off function	<input type="radio"/>	Conditions set by the user program
Auto tray switching	<input type="radio"/>	
Message display	<input type="radio"/>	(FAX/Printer extension) (AR-F201 standard)
User program	<input type="radio"/>	
Total counter	<input type="radio"/>	

: Available

X : Not available

* : By the document size set key

: When an option is installed

P. Other specifications

Photoconductor type	OPC (Organic Photo Conductor)
Photoconductor drum dia.	30mm
Copy lamp	Xenon lamp
Developing system	Dry 2-component magnetic brush development
Charging system	Saw teeth charging
Transfer system	(+) DC corotron
Separation system	(-) DC corotron
Fusing system	Heat roller
Cleaning system	Contact blade

Q. Package form

Body	Body/Accessories
------	------------------

R. External view

External dimensions (W × D × H)	590 × 531 × 470 mm (AR-162/163) 590 × 531 × 523mm (AR-201/206) 590 × 531 × 650mm (AR-207/F201)
Occupying area (W × D)	590 × 531mm (When the manual tray is installed.)
Weight	About 32kg (AR-162/163) About 35.7kg (AR-201) About 36.2kg (AR-206) About 43kg (AR-207)

S. Power source

Voltage	AC120V, 220V, 230V, 240V ± 15%
Frequency	50/60Hz common

T. Power consumption

Max. power consumption	About 1.3KWh
------------------------	--------------

* EnergyStar standard (The 2nd level conformity)

Pre-heat	About 60Wh
Auto power shut off	0wh about 4.8wh (when FAX or the printer expansion kit is installed)

U. Digital performance

Resolution	Reading	400 dpi
	Writing	600 dpi
Gradation	Reading	256 gradations
	Writing	Binary

[3] CONSUMABLE PARTS

1. Supply system table

A. USA/CANADA/Latin America

NO	Name	Content	Life	Model name	Remark
1	Toner cartridge (Black) <With IC>	Toner (Toner: Net Weight 475g) Vinyl bag	× 1 × 1	13K AR-201NT (AR-201-J*1)	Life setting by A4 6% document <Not compatible with the AR-160/200/225>
2	Developer	Developer (Developer: Net Weight 400g) Vinyl bag	× 1 × 1	30K AR-201ND	<Not compatible with the AR-160/200/225>
3	Drum kit	Drum Drum fixing plate	× 1 × 1	30K AR-201DR	The AR-201 DR/DM can be used instead of the AR-200 MR/LR/CR.

*1: For USA government

B. Middle East/Africa

NO	Name	Content	Life	Model name	Remark
1	Toner cartridge (Black) <With IC>	Toner (Toner: Net Weight 475g) Vinyl bag	× 1 × 1	13K AR-201FT	Life setting by A4 6% document <Not compatible with the AR-160/200/225>
2	Developer	Developer (Developer: Net Weight 400g) Vinyl bag	× 1 × 1	30K AR-201SD	<Not compatible with the AR-160/200/225>
3	Drum kit	Drum Drum fixing plate	× 1 × 1	30K AR-201DR	The AR-201 DR/DM can be used instead of the AR-200 MR/LR/CR.

C. Europe/East Europe

NO	Name	Content	Life	Model name	Remark
1	Toner cartridge (Black) <With IC>	Toner (Toner: Net Weight 475g) Vinyl bag	× 1 × 1	13K AR-201T	Life setting by A4 6% document <Not compatible with the AR-160/200/225>
2	Developer	Developer (Developer: Net Weight 400g) Vinyl bag	× 1 × 1	30K AR-201DV	<Not compatible with the AR-160/200/225>
3	Drum kit	Drum Drum fixing plate	× 1 × 1	30K AR-201DM	The AR-201 DR/DM can be used instead of the AR-200 MR/LR/CR.

D. Asia

NO	Name	Content	Life	Model name	Remark
1	Toner cartridge (Black) <With IC>	Toner (Toner: Net Weight 475g) Vinyl bag	× 1 × 1	13K AR-201ST	Life setting by A4 6% document <Not compatible with the AR-160/200/225>
2	Developer	Developer (Developer: Net Weight 400g) Vinyl bag	× 1 × 1	30K AR-201SD	<Not compatible with the AR-160/200/225>
3	Drum kit	Drum Drum fixing plate	× 1 × 1	30K AR-201DR	The AR-201 DR/DM can be used instead of the AR-200 MR/LR/CR.

E. Hong Kong/China

NO	Name	Content	Life	Model name	Remark
1	Toner cartridge (Black) <With IC>	Toner (Toner: Net Weight 475g) Vinyl bag	× 1 × 1	13K AR-201ST-C	Life setting by A4 6% document <Not compatible with the AR-160/200/225>
2	Developer	Developer (Developer: Net Weight 400g) Vinyl bag	× 1 × 1	30K AR-201SD-C	<Not compatible with the AR-160/200/225>
3	Drum kit	Drum Drum fixing plate	× 1 × 1	30K AR-201DR-C	The AR-201 DR/DM can be used instead of the AR-200 MR/LR/CR.

2. Environment conditions

A. Transport condition

(1) Transport conditions

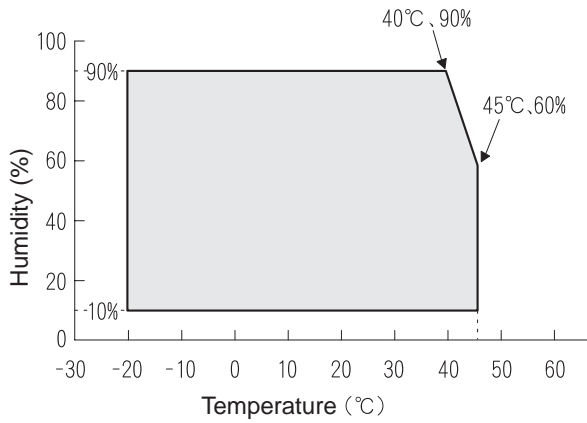

(2) Storage conditions (packed conditions)

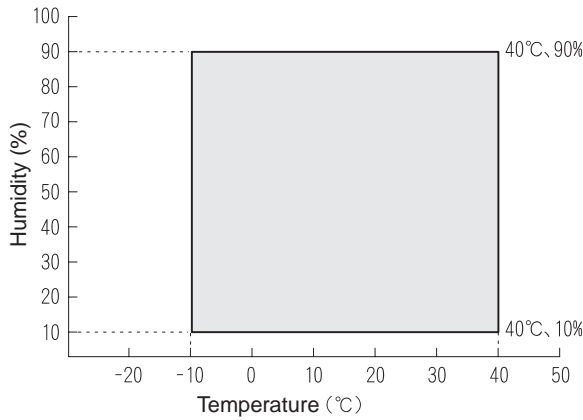

B. Use conditions

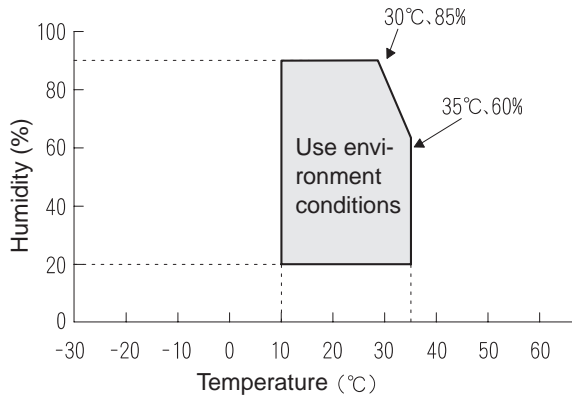

C. Life (packed conditions)

Photoconductor drum (36 months from the production month)

Developer, toner (24 months from the production month)

3. Production number identification

<Toner cartridge>

The label on the toner cartridge shows the date of production.

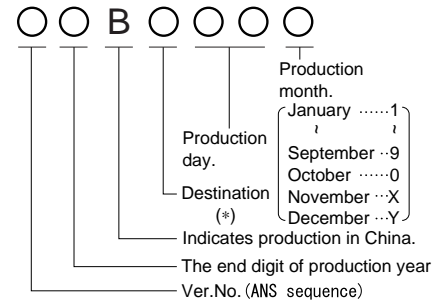

*: Destination

Division	No.
Japan option	1
Ex option	2
Japan, same pack	6
Ex, same pack	7

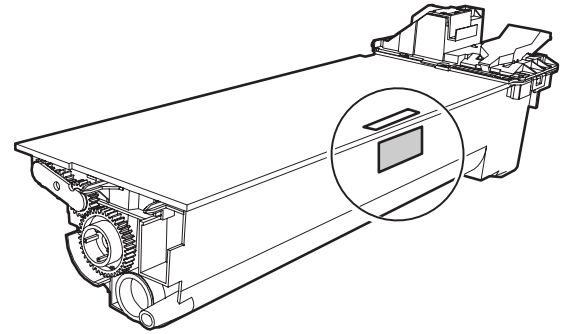

<Drum cartridge>

The label on the drum cartridge shows the date of production.

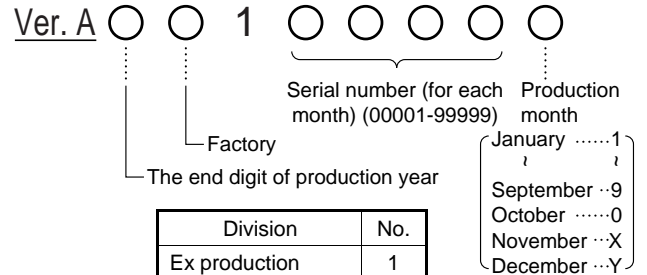

Division	No.
Ex production	1
Option	2
Same pack	3

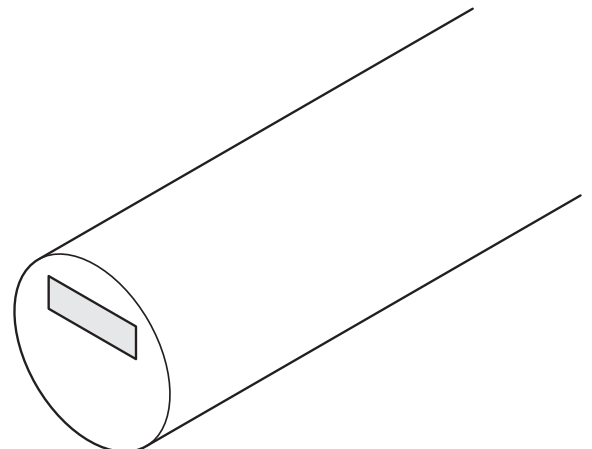

[4] EXTERNAL VIEWS AND INTERNAL STRUCTURES

1. Appearance

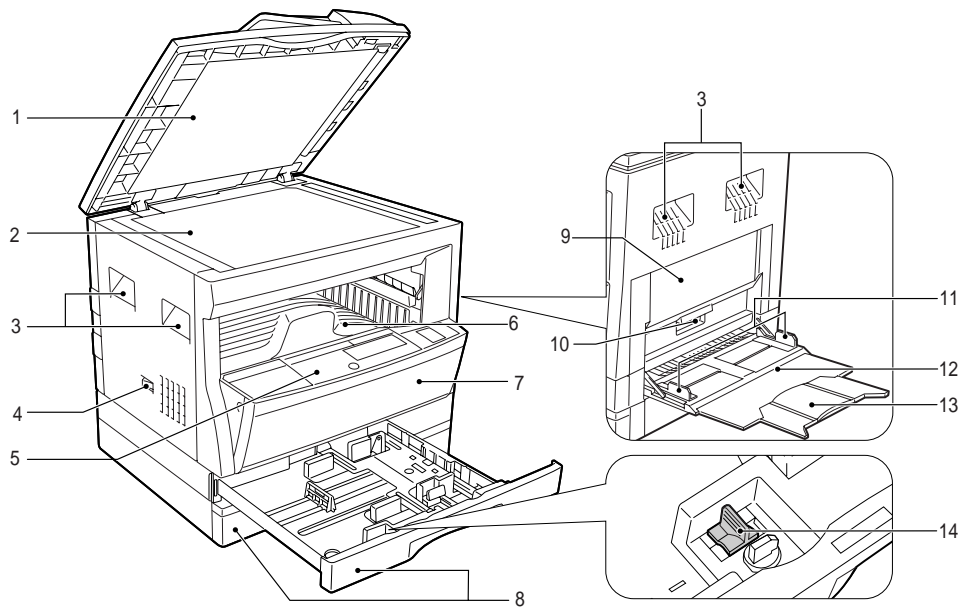

1	Document feeder cover	2	Original table	3	Handles
4	Power switch	5	Operation panel	6	Paper output tray
7	Front cover	8	Paper trays	9	Side cover
10	Side cover handle	11	Bypass tray guides	12	Bypass tray
13	Bypass tray extension	14	Charger cleaner		

* The AR-162/163 are equipped with one paper tray.

2. Internal

Reversing single pass feeder (RSPF)

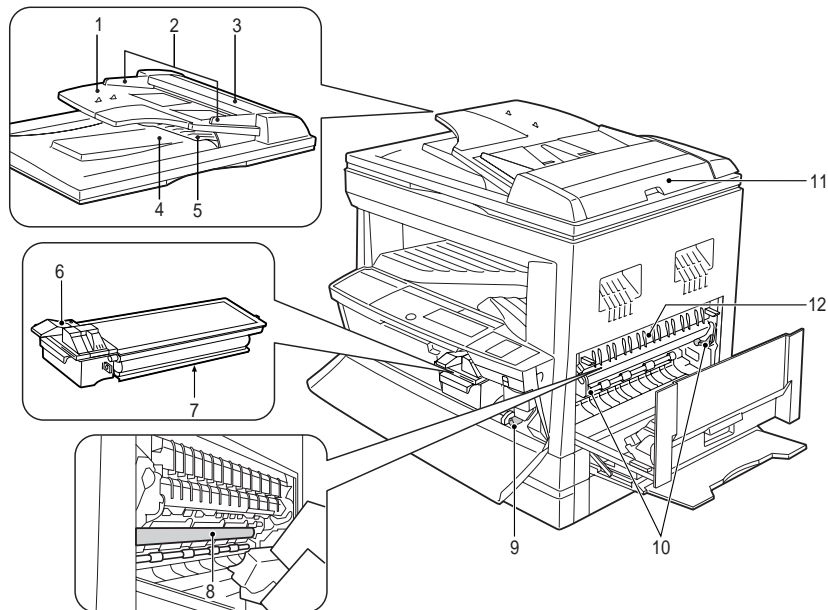

1	Document feeder tray	2	Original guides	3	Feeding roller cover
4	Exit area	5	Reversing tray	6	Toner cartridge lock release lever
7	Toner cartridge	8	Photoconductive drum	9	Roller rotating knob
10	Fusing unit release levers	11	Right side cover	12	Paper guide

3. Operation Section

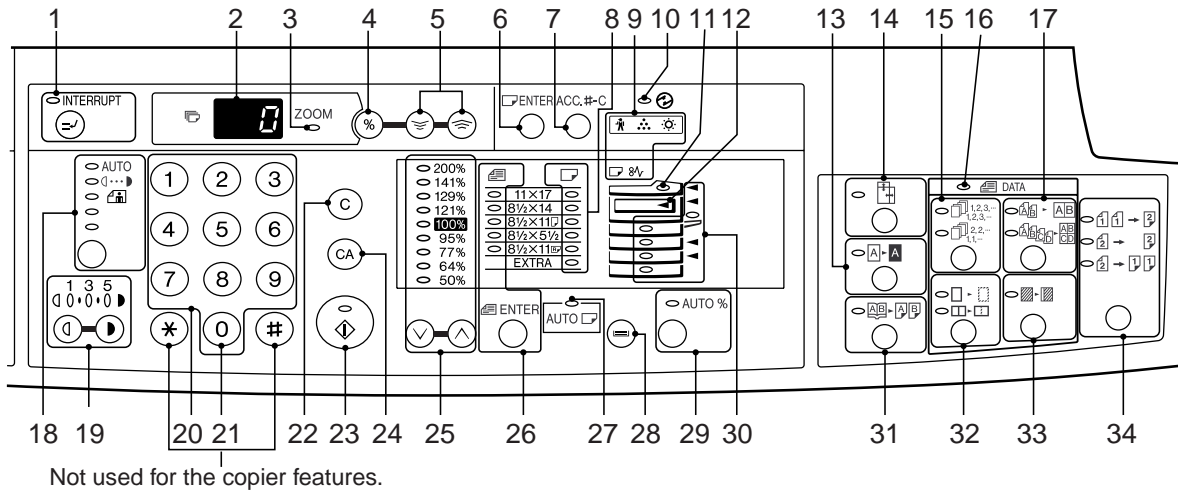

1	INTERRUPT key and indicator	2	Copy quantity display	3	ZOOM indicator
4	Copy ratio display key	5	Zoom keys	6	PAPER SIZE ENTER key
7	AUDIT CLEAR key	8	PAPER SIZE indicators	9	Alarm indicators *2
10	POWER SAVE indicator	11	SPF/RSPF indicator	12	Output tray full indicator
13	B/W REVERSE key and indicator	14	XY-ZOOM key and indicator	15	SORT/GROUP key and indicators
16	ORIGINAL DATA indicator	17	2 IN 1 / 4 IN 1 key and indicators	18	AUTO/MANUAL/PHOTO key and indicators
19	Light and dark keys and indicators *3	20	Numeric keys	21	Zero key *4
22	CLEAR key	23	START key and indicator	24	CLEAR ALL key
25	PRESET RATIO selector keys and indicators	26	ORIGINAL SIZE ENTER key and indicators	27	AUTO PAPER SELECT indicator
28	TRAY SELECT key	29	AUTO IMAGE key and indicator	30	Paper feed location/misfeed location indicators
31	DUAL PAGE COPY key and indicator	32	ERASE key and indicators	33	MARGIN SHIFT key and indicator
34	ORIGINAL TO COPY key and indicators				

*1

ON: Indicates that the machine is in the energy saving (pre-heat) mode.

Blink: Indicates that the machine is in the process of resetting from the energy saving mode or just after supplying the power. (During warmup)

OFF: Indicates that resetting from the energy saving mode is completed and that the fusing temperature is in ready state.

The combinations of the above display lamps are as follows:

(○ = ON, ● = OFF)

Lamp	Immediately after power ON	Ready	Copying
Pre-heat lamp	Blink	●	●
Ready lamp	○	○	●
Other lamps	○	○	○

Lamp	Energy saving mode (Pre-heating)	Energy saving mode (Auto power shut off)	Resetting from energy saving mode	Copy is started during resetting from energy saving mode
Pre-heat lamp	○	○	Blink	Blink
Ready lamp	○	●	○	●
Other lamps	○	●	○	○

*2

Maintenance indicator
When the set count number (set by the simulation) is reached, the lamp lights up. The machine does not stop.

Toner cartridge replacement required indicator
When toner density is lower than a specified level, the TONER CARTRIDGE REPLACEMENT indicator lights up to warn the user.
If toner is not added after approximately 10% is copied, the indicator starts blinking and machine starts to supply toner. (Toner cartridge replacement indicator keeps lighting up)
If toner density is not back to specific level after two minutes, the READ indicator goes out and Toner indicator starts blinking, and the copier stops.

Developer replacement required indicator

(1) Lights up when the developer counter reaches 30K.

(2) Selection between STOP and NON-STOP is allowed with the service simulation No. (Default: NON-STOP)

Paper required indicator

Misfeed indicator

*3 Light key

Press and hold this key for 5 sec, and the machine will enter the user program mode.

*4 Zero key

Press and hold this key, and the total output counter value is displayed on the copy quantity display.

4. Motor, solenoid, clutch

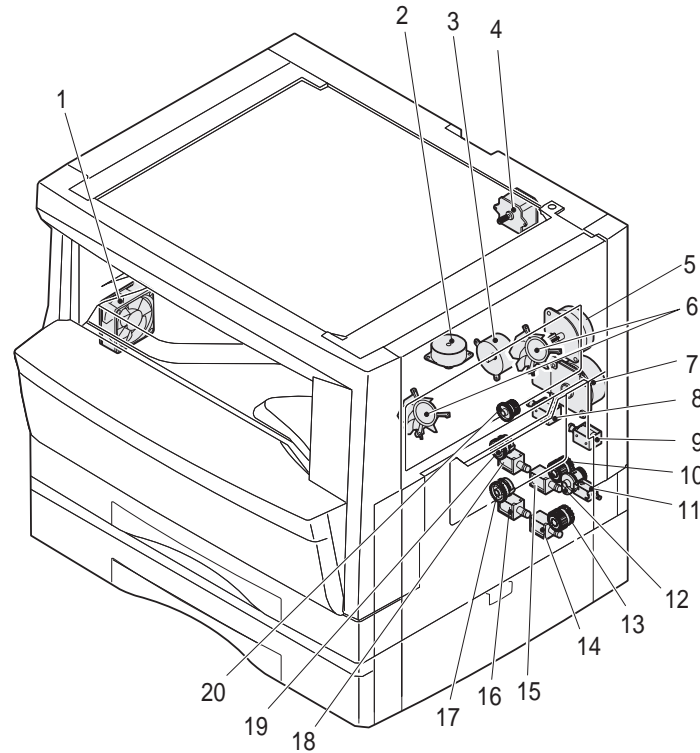

No.	Name	Code	Function, operation
1	Exhaust fan motor	VFM	Cools the inside of the machine.
2	Shifter motor	SHTM	Shifts the paper exit tray. (Except for the AR-162)
3	Toner motor	TM	Toner supply
4	Mirror motor	MRM	Drives the optical mirror base (scanner unit).
5	Duplex motor	DPX	Switchback operation and paper exit motor in duplex. (only AR-206/207)
6	Cooling fan motor	CFM	Cools the inside of the machine.
7	Main motor	MM	Drives the machine.
8	Paper feed solenoid	CPFS1	Solenoid for paper feed from cassette
9	Resist roller solenoid	RRS	Resist roller rotation control solenoid
10	Manual paper feed clutch	MPFC	Drives the manual paper feed roller.
11	Manual paper feed solenoid	MPFS	Manual paper feed solenoid
12	Manual paper transport clutch	MPTC	Drives the manual paper transport roller.
13	2nd tray transport clutch	CPFC2	Drives the 2nd tray transport roller.
14	2nd tray transport solenoid	FSOL2	2nd tray transport solenoid
15	1st tray transport solenoid	FSOL1	1st tray transport solenoid
16	2nd tray paper feed solenoid	PSOL2	2nd tray transport solenoid
17	Paper feed clutch	CPFC2	Drives the cassette paper feed roller.
18	1st tray paper feed solenoid	PSOL1	1st tray transport solenoid
19	1st tray paper feed clutch	CPFC1	Drives the 1st tray transport roller.
20	PS clutch	RRC	Drives the resist roller

5. Sensor, switch

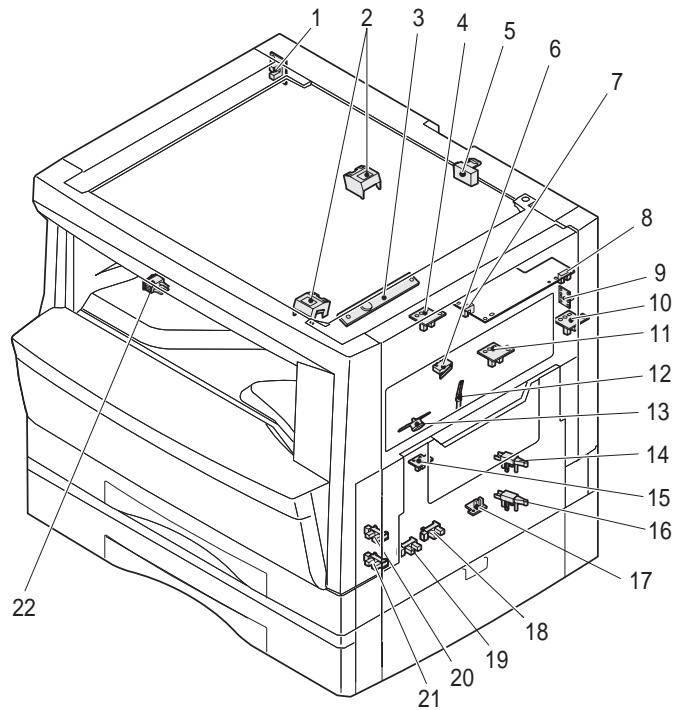

No.	Name	Code	Function, operation
1	Mirror home position sensor	MHPS	Detects the mirror (scanner unit) home position.
2	Document size sensor	DSIN	Paper size detection
3	Toner density sensor	TCS	Toner quantity detection
4	Paper exit sensor (paper exit side)	POD1	Detects paper exit.
5	OC open/close sensor	DOC COVER	Detects open/close of OC/SPF.
6	Right door switch	DSWR	Side door open/close detection
7	Paper full sensor	P FULL	Paper exit tray section full detection <For JOB separator>
8	Lift sensor	LFTHP	Paper feed tray lift up detection <For JOB separator>
9	Lower limit sensor	JTRAY	Job separator tray lower limit detection
10	Paper exit sensor (DUP side)	PDPX	Paper transport detection
11	Shifter home position sensor	SFTHP	Shifter home position detection (Excluding AR-162)
12	Thermistor	RTH	Fusing section temperature detection
13	Thermostat		Fusing section abnormally high temperature detection
14	1st tray detection switch		1st tray detection
15	Paper in	PIN	Paper transport detection
16	2nd tray detection switch		2nd tray detection (Excluding AR-162/163)
17	Manual sensor	MPED	Manual transport detection
18	2nd tray door open/close sensor	DRS2	2nd tray door open/close detection (Excluding AR-162/163)
19	2nd tray paper entry sensor	PPD2	Paper transport detection (Excluding AR-162/163)
20	1st tray paper empty sensor	CSS1	1st tray paper empty detection
21	2nd tray paper empty sensor	CSS2	2nd tray paper empty detection (Excluding AR-162/163)
22	Power switch	MAIN SW	Turns ON/OFF the main power source.

6. PWB unit

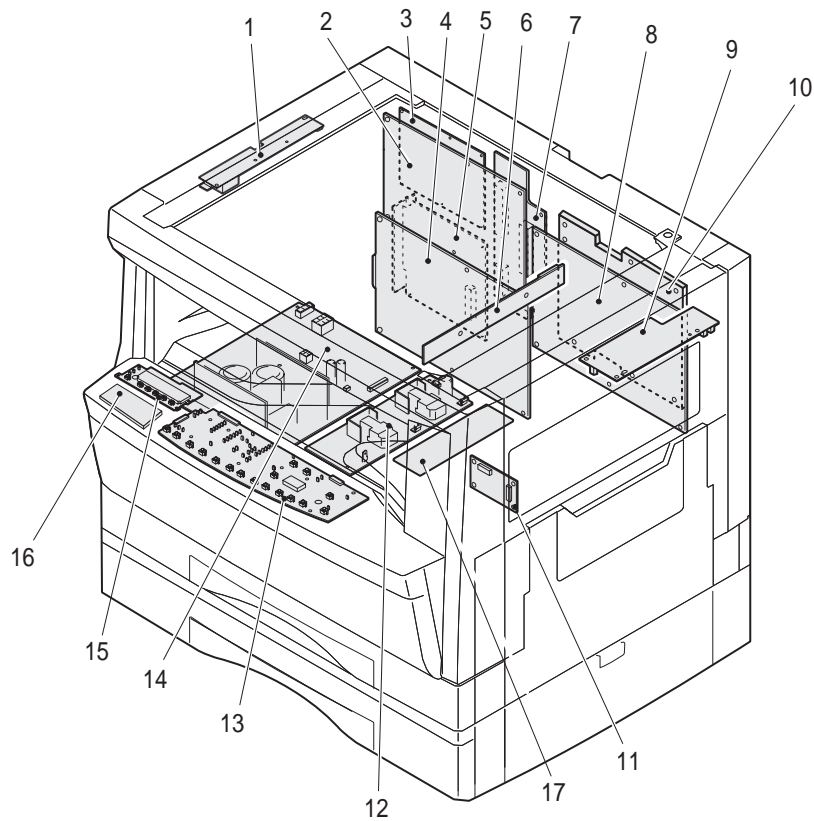

No.	Name	Function, operation
No.	Name	Function, operation
1	Copy lamp Inverter PWB	Copy lamp control
2	FAX main PWB	Fax communication control <AR-F201 or Option>
3	TEL/LIU PWB	Line control (Fax communication) <AR-F201 or Option>
4	Printer control PWB	Printer control <Option>
5	Network Board	Network system interface <Option>
6	CCD sensor PWB	Image scanning
7	Mother PWB	Connecting the MCU and Printer/FAX PWB <AR-F201 or Option>
8	Main PWB (MCU)	Machine control/Image process
9	Paper exit interface PWB	Paper exit, finishing control
10	Electronic sort PWB	Electronic sort function control <AR-207 or Option>
11	Tray interface PWB	Paper tray control
12	High voltage PWB	High voltage control
13	Operation main PWB	Operation panel input/Display, operation panel section control
14	Power PWB	AC power input/DC power control
15	LCD PWB	Printer and FAX status display <AR-F201 or Option>
16	Fax operation PWB	Operation for FAX <AR-F201 or Option>
17	CRUM PWB	Saving toner cartridge data

7. Cross sectional view

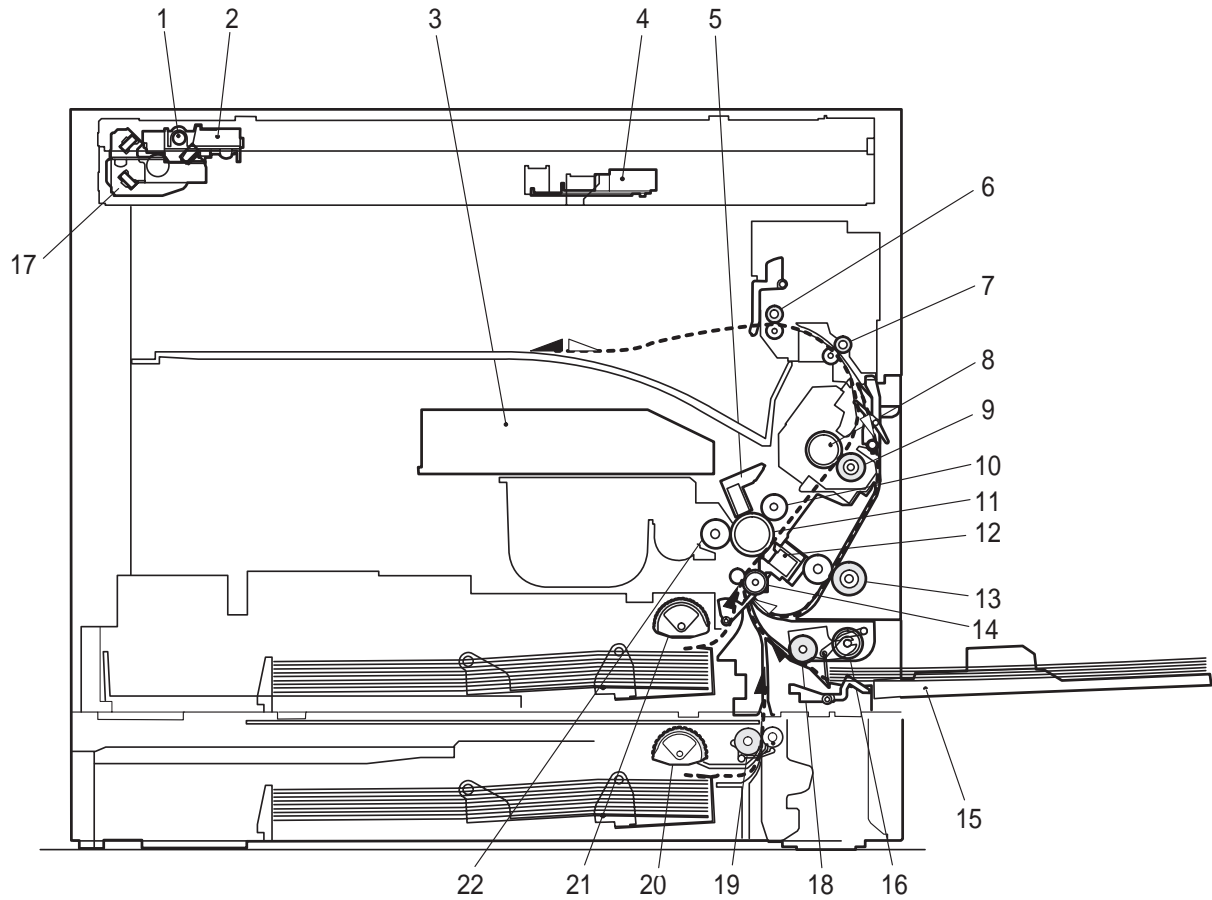

No.	Name	Function/Operation
1	Copy lamp	Image radiation lamp
2	Copy lamp unit	Operates in synchronization with No. 2/3 mirror unit to radiate documents sequentially.
3	LSU unit	Converts image signals into laser beams to write on the drum.
4	Lens unit	Reads images with the lens and the CCD.
5	MC holder unit	Supplies negative charges evenly on the drum.
6	Paper exit roller	Used to discharge paper.
7	Transport roller	Used to transport paper.
8	Upper heat roller	Fuses toner on paper (with the teflon roller).
9	Lower heat roller	Fuses toner on paper (with the silicon rubber roller).
10	Waste toner transport roller	Transports waste toner to the waste toner box.
11	Drum unit	Forms images.
12	Transfer charger unit	Transfer images (on the drum) onto paper.
13	Duplex transport roller	Transports paper for duplex (only AR-206/207).
14	Resist roller	Takes synchronization between the paper lead edge and the image lead edge.
15	Manual paper feed tray	Manual paper feed tray
16	Manual paper feed roller	Picks up paper in manual paper feed.
17	No. 2/3 mirror unit	Reflects the images from the copy lamp unit to the lens unit.
18	Manual transport roller	Transports paper from the manual paper feed port.
19	2nd tray paper transport roller	Transports paper from the 2nd tray. (Excluding AR-162/163)
20	2nd tray paper feed roller (semi-circular roller)	Picks up paper from the 2nd tray. (Excluding AR-162/163)
21	1st tray paper feed roller (semi-circular roller)	Picks up paper from the 1st tray.
22	MG roller	Puts toner on the OPC drum.

[5] UNPACKING AND INSTALLATION

1. Installing conditions

1) Copier installation

Do not install your copier in areas that are:

- damp, humid, or very dusty
- exposed to direct sunlight
- poorly ventilated
- subject to extreme temperature or humidity changes, e.g., near an air conditioner or heater.
- Be sure to allow the required space around the machine for servicing and proper ventilation.

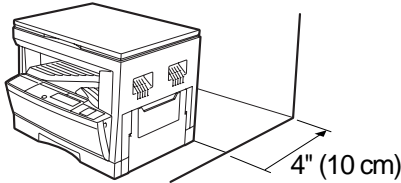

2) Power source

- Use an exclusive-use power outlet. If the power plug of this machine is inserted into a power outlet commonly used with other illumination units, flickers of the lamp may be result. Use a power outlet which is not used commonly with any illumination units.
- Avoid complex wiring.

3) Grounding wire connection.

- To avoid danger, be sure to connect a grounding wire. If no grounding wire is connected and a leakage occurs, a fire or an electric shock may be result.

2. Removal of protective material and fixing screw

1) Remove all tapes and protective material.

- Remove all tapes, then open the document cover and remove the protective material of sheet shape

2) Remove the fixing screw.

- Use a coin to remove the fixing screw.
- The fixing screw is required when transporting the machine. Keep it in the tray. (Refer to the later description.)

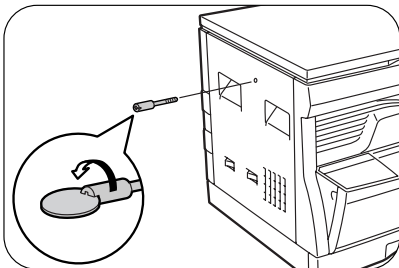

3. Installing procedure

A. Developer cartridge installation

1) Open the manual tray, and open the side cover.

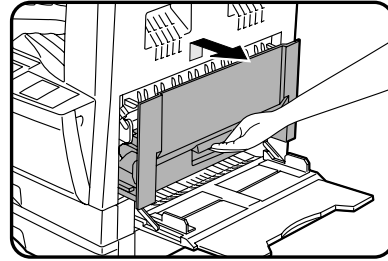

2) Open the front cover.

- Hold the both sides and pull down to open.

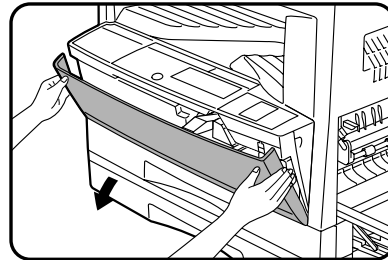

3) Loosen the screw and remove the developer cartridge.

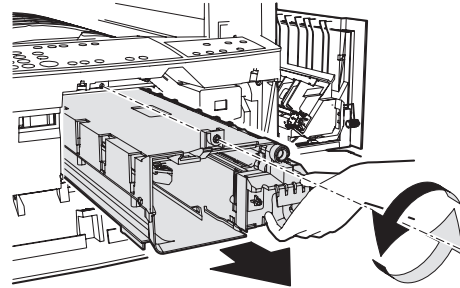

4) Remove the developer tank from the developer cartridge.

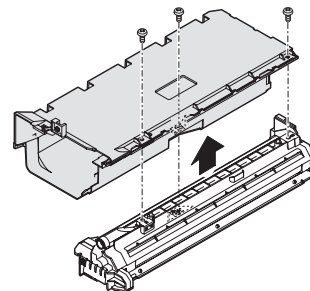

5) Supply developer into the developer tank while rotating the MG roller.

- * Shake the developer bag enough before opening it.

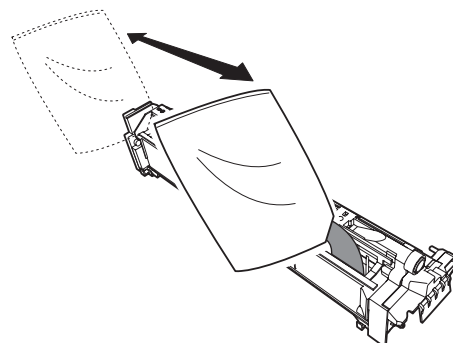

- 6) Attach the developer tank to the developer cartridge.
 - * After supplying developer into the developer cartridge, do not tilt or shake the developer cartridge.
- 7) Attach the developer cartridge to the copier, and fix it with the screw.

B. Toner cartridge installation

- 1) Shake the toner cartridge several times horizontally, and remove the tape.
 - * Do not hold the shutter lever when shaking.
 - * After removing the tape, do not tilt or shake the toner cartridge.

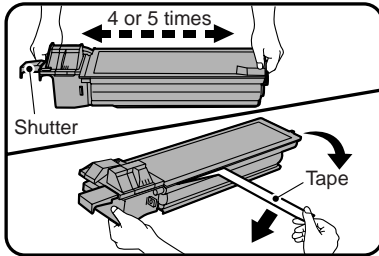

- 2) Attach the toner cartridge to the copier.

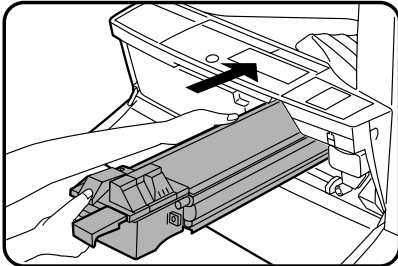

- 3) Pull the shutter lever.

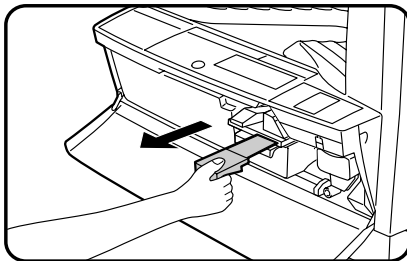

Close the front cover A, then close the side cover B.

- When closing the front cover, gently press the both sides.
- When closing the side cover, hold the knob.
- When closing the covers, be sure to close the front cover first, then close the side cover. If closed in a wrong sequence, the covers may be broken.

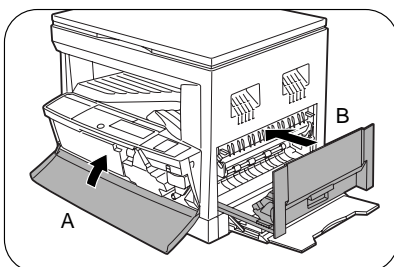

4. Removal and storage of fixing screw

- 1) Lift the knob and gently pull out the tray.

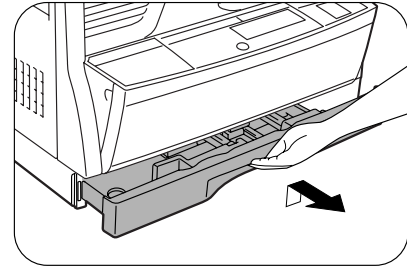

- 2) Hold the paper pressure plate and turn the fixing screw in the arrow direction.

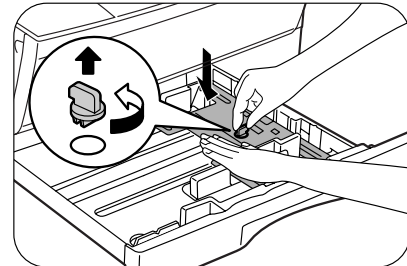

- 3) Store the fixing pin and the fixing screw in the tray.

- Store the fixing screw which was removed in the above procedure 2 and the fixing screw which was removed in procedure 2 of 2.
- Removal of protective material and fixing screw in the storage place in the tray.

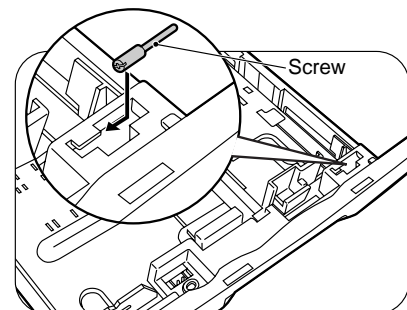
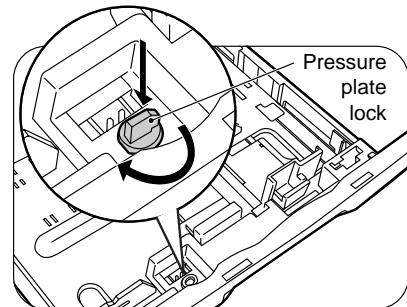

5. Changing the copy paper size in the tray

- 1) Gently lift and pull out the paper tray until it stops.
- 2) Push the pressure plate down until it locks in place.
- 3) Squeeze the lock lever of the front guide and slide the front guide to match the width of the paper.

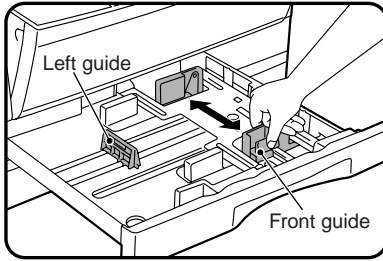

- 4) Move the left guide to the appropriate slot as marked on the tray.
 - When using 11" x 17" copy paper, store the left guide in the slot at the left front of the paper tray.

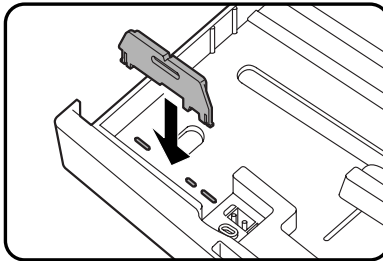

- 5) Load copy paper into the tray.
- 6) Place the paper size plate in the front of the paper tray.
 - The paper size indication which shows through the slot on the front of the copier should match the selected paper size.
- 7) Push the paper tray firmly back into the copier.
- 8) To set the selected paper size, press and hold down the PAPER SIZE ENTER key. The selected paper feed location indicator and the corresponding paper size (which has been set) indicator will blink. All other indicators will go out.
 - For paper size setting, ensure that the COPY mode has been selected. However, if printer or facsimile output is being performed, paper size setting cannot be made even in the COPY mode.

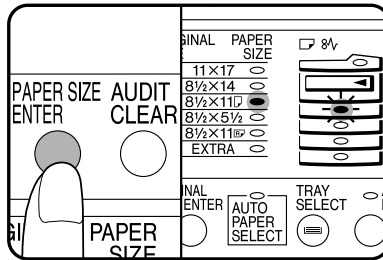

- 9) Use the TRAY SELECT key to select the paper tray of which the paper size has been changed.
 - Each time the TRAY SELECT key is pressed, a paper tray is indicated with a blinking paper feed location indicator. If an optional paper feed unit is not installed, this operation is not needed.

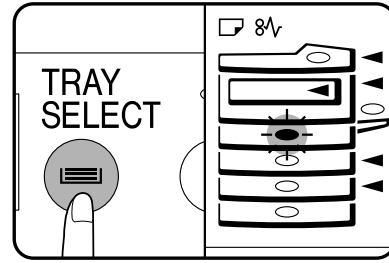

- 10) Use the ORIGINAL SIZE ENTER key to select the paper size which is set.
 - Each time the ORIGINAL SIZE ENTER key is pressed, a paper size will be indicated with a blinking paper size indicator.

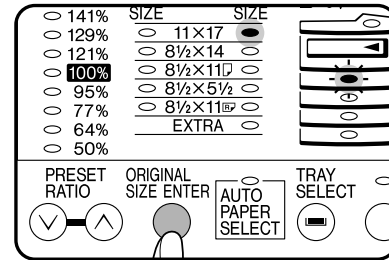

- 11) Press the START key and then the PAPER SIZE ENTER key.
 - To change the paper size setting of another tray, repeat steps 9 to 10 after pressing the START key.

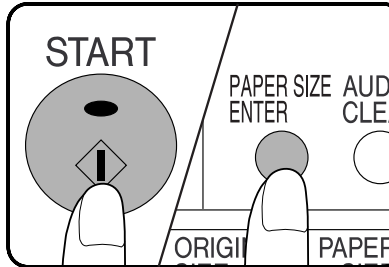

[6] ADJUSTMENTS

1. Adjustment item list

Section		Adjustment item		Adjustment procedure/SIM No.	
A	Process section	(1)	Developing doctor gap adjustment	Developing doctor gap adjustment	
		(2)	MG roller main pole position adjustment	MG roller main pole position adjustment	
		(3)	Developing bias voltage output adjustment		
		(4)	Main charger voltage output adjustment		
B	Mechanism section	(1)	Image lead edge position adjustment	SIM 50-1	
		(2)	Main scanning direction (FR direction) distortion balance adjustment	No. 2/3 mirror base unit installing position adjustment	
				Copy lamp unit installing position adjustment	
		(3)	Main scanning direction (FR direction) distortion adjustment	Rail height adjustment	
		(4)	Sub scanning direction (scanning direction) distortion adjustment	Winding pulley position adjustment	
		(5)	Main scanning direction (FR direction) magnification ratio adjustment	SIM 48-1	
		(6)	Sub scanning direction (scanning direction) magnification ratio adjustment	a	OC mode in copying (SIM 48-2)
				b	SPF mode in copying (SIM 48-5)
				c	OC mode in FAX (SIM 48-6)
d	SPF mode in FAX (SIM 48-7)				
(7)	Off center adjustment	a	OC mode (SIM 50-13)		
		b	SPF mode (SIM 50-16)		
(8)	OC (SPF) open/close detection position adjustment	OC (SPF) open/close detection position adjustment			
(9)	Document size detection sensor	SIM 41-3			
C	Image density adjustment	(1)	Copy mode	SIM 46-1	

2. Copier adjustment

A. Process section

(1) Developing doctor gap adjustment

- Loosen the developing doctor fixing screw A.
- Insert a thickness gauge of 1.5mm to the three positions at 20mm and 130mm from the both ends of the developing doctor as shown.

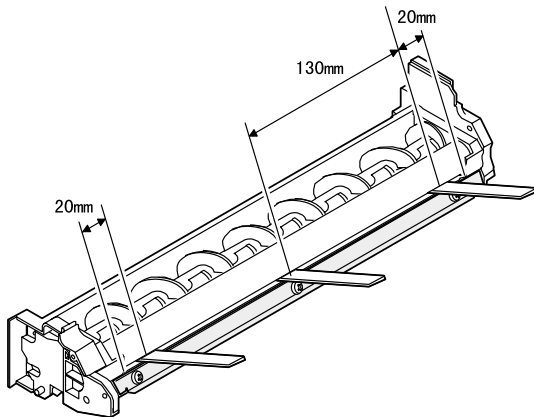

- Push the developing doctor in the arrow direction, and tighten the developing doctor fixing screw. (Perform the same procedure for the front and the rear frames.)
- Check the clearance of the developing doctor. If it is within the specified range, then fix the doctor fixing screw with screw lock.

* When inserting a thickness gauge, be careful not to scratch the developing doctor and the MG roller.

<Adjustment specification>

Developing doctor gap

Both ends (20mm from the both ends): $1.5^{+0.15}_0$ mm

C (Center)(150mm from the both ends): $1.55^{+0.15}_0$ mm

(2) MG roller main pole position adjustment

- Remove and separate the waste toner box and put the developing unit on a flat surface.
- Tie a string to a needle or a pin.
- Hold the string and bring the needle close to the MG roller horizontally. (Do not use paper clip, which is too heavy to make a correct adjustment.) (Put the developing unit horizontally for this adjustment.)
- Do not bring the needle into contact with the MG roller, but bring it to a position 2 or 3mm apart from the MG roller. Mark the point on the MG roller which is on the extension line from the needle tip.
- Measure the distance from the marking position to the top of the doctor plate of the developing unit to insure that it is 18mm. If the distance is not within the specified range, loosen the fixing screw A of the main pole adjustment plate, and move the adjustment plate in the arrow direction to adjust.

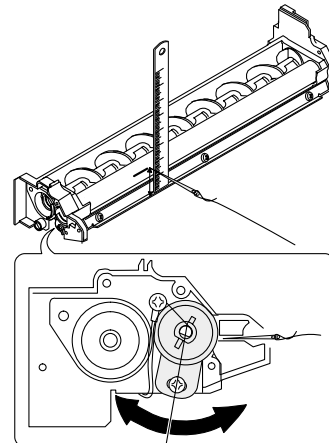

(3) Developing bias voltage adjustment

Note: • Use a digital multi-meter with an internal resistance of 10MΩ or more.

- 1) Set the digital multi-meter range to DC700V.
- 2) Put the test rod of the digital multi-meter on the developing bias voltage output check pin.
- 3) Turn on the power.
- 4) Adjust the adjustment volume VR31 so that the output voltage is within the specified range shown below.

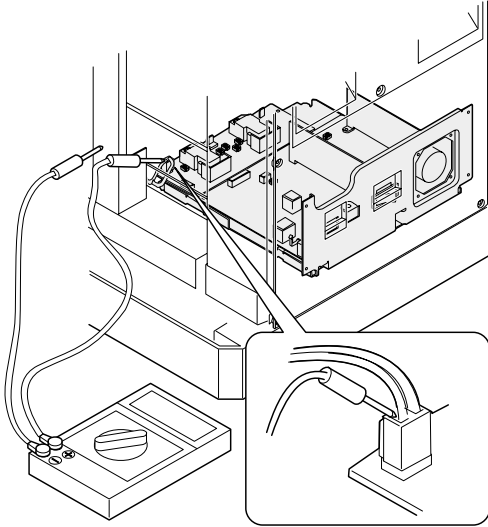

<Adjustment specification>

Mode	Specification	
Developing bias voltage	DC-400±8V	VR31

(4) Grid bias voltage adjustment

Note: • Use a digital multi-meter with an internal resistance of 10MΩ or more.

- 1) Set the digital multi-meter range to DC700V.
- 2) Put the test rod of the digital multi-meter on the grid bias voltage output check pin.
- 3) Turn on the power.
- 4) Adjust the adjustment volumes (VR51, VR52) so that the output voltage is within the specified range. (The voltage is outputted in the grid bias high output mode during warming up, and in the grid bias low output mode after completion of warming up.)

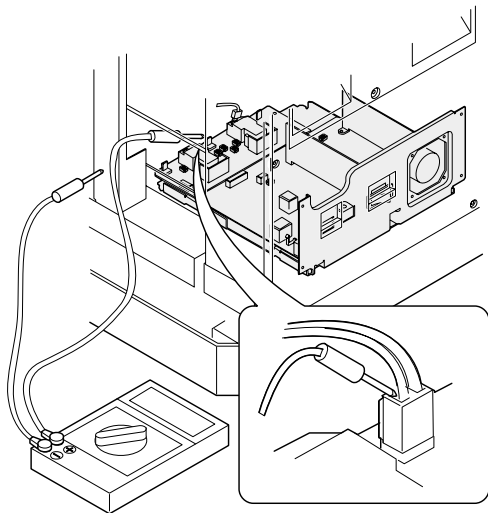

<Adjustment specification>

Mode	Specification	
Grid bias LOW	DC-400±20V	VR52
Grid bias HIGH	DC-525±10V	VR51

B. Mechanism section

(1) Image lead edge position adjustment (SIM 50-1)

a. OC image lead edge position adjustment

Note: In advance to this adjustment, the sub scanning magnification ratio adjustment must be performed.

- 1) Set a scale on the OC table as shown below.

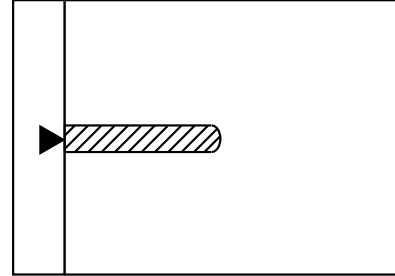

- 2) Make a copy.
- 3) Check the copy output. If necessary, perform the following adjustment procedures.
- 4) Execute SIM 50-1.
- 5) Set the OC lead edge position set value (Exposure display <AUTO> ON) to "99."
The OC image scanning start position is shifted inside the document edge.
- 6) Set the main cassette lead edge void adjustment value (Exposure display <PHOTO> ON) * to "1."
The lead edge void becomes the minimum.
- 7) Set the print start position value (Exposure display <EXP1> ON) to "99" and make a copy.
The print start position is shifted inside the document edge.

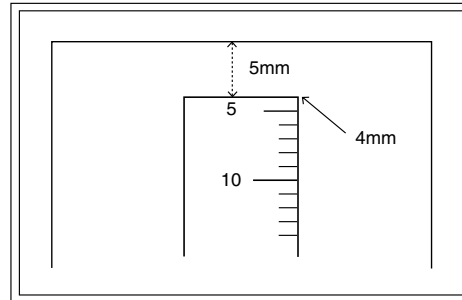

*The dimension varies depending on the model.

- 8) Measure the image loss R of the copied image. Enter the set value of the image scanning lead edge position (Exposure display <AUTO> ON) again.
 - 1 step of the set value corresponds to about 0.127mm shift.
 - Calculate the set value from the formula below.
$$99 - R/0.127 \text{ (mm)} = \text{Image loss set value} <R: \text{Image loss measurement value (mm)}>$$

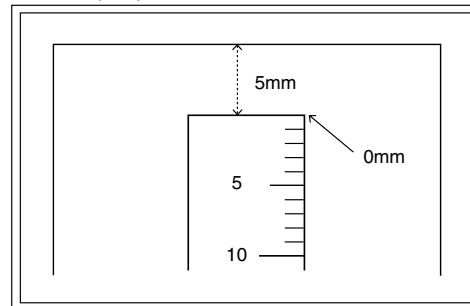

* The scanning edge is set.
(A line may be printed by scanning the document edge.)

Example: $99 - 4/0.127 = 99 - 31.5 = \text{about } 67$

Note: If the set value is not obtained from the above formula, perform the fine adjustment.

- 9) Measure the distance H between the paper lead edge and the image print start position. Set the image print start position set value (Exposure display <EXP> ON) again.
- 1 step of the set value corresponds to about 0.127mm shift.
 - Calculate the set value from the formula below.
- $99 - H/0.127$ (mm) = Image print start position set value <H: Print start position measurement value (mm)>

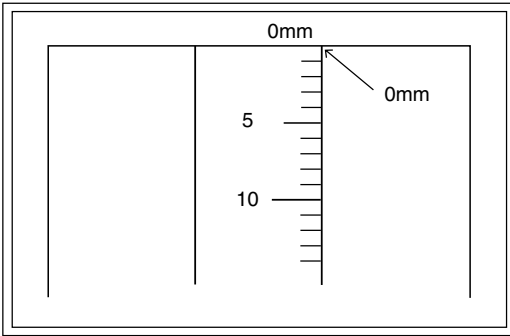

*Fit the print edge with the paper edge, and perform the lead edge adjustment.

Example: $99 - 5/0.127 = 99 - 39.4 =$ about 59

Note: If the set value is not obtained from the above formula, perform the fine adjustment.

- 10) Set the main cassette lead edge void adjustment value (Exposure display <PHOTO> ON)* again.
- 1 step of the set value corresponds to about 0.127mm shift.
 - Calculate the set value from the formula below.
- $B/0.127$ (mm) = Lead edge void adjustment value <B: Lead edge void (mm)>

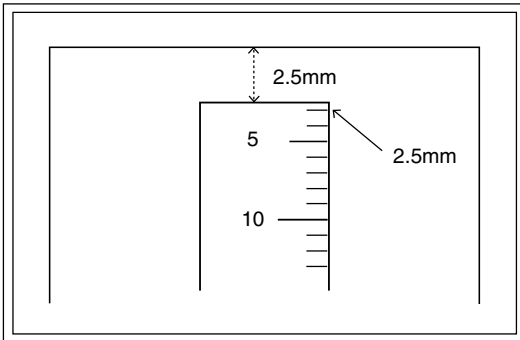

Example: When setting the lead edge void to 2.5mm:
 $2.5 / 0.127 =$ about 20

Note: If the set value is not obtained from the above formula, perform the fine adjustment.

- * 2nd tray lead edge void adjustment: Exposure display <AUTO + MANUAL + PHOTO>
- Multi bypass tray lead edge void adjustment: Exposure display <MANUAL + PHOTO>

OC 2nd print surface (Auto duplex) lead edge position adjustment: Density display <EXP3>

OC 2nd print surface (Auto duplex) lead edge void adjustment: Exposure display <None>

* For the adjustment procedure, set to S → D mode

Note: Before performing the 2nd print surface lead edge position adjustment and the lead edge void adjustment, be sure to perform the 1st print surface lead edge position adjustment in advance, and be sure to perform the 2nd print surface lead edge position adjustment and then the lead edge void adjustment in this sequence.

<Adjustment specification>

Adjustment mode	SIM	LED	Set value	Spec value	Set range
OC image lead edge position		AUTO	99 R/0.127		
Main cassette lead edge void	SIM 50-1	PHOTO	B/0.127	Lead edge void: 1 - 4mm Image loss: 3mm or less	1 ~ 99
2nd tray lead edge void		AUTO + MANUAL + PHOTO			
Multi bypass tray lead edge void		MANUAL + PHOTO			
Print start position		EXP1	99 - H/0.127		
OC 2nd print surface lead edge position adjustment	SIM 50-1*	EXP 3	1 step: 0.127mm shift		
OC 2nd print surface lead edge void adjustment		No display	1 step: 0.127mm shift		

* (Set to S → D mode for before execution)

b. SPF image lead edge position adjustment

- 1) Set a scale on the OC table as shown below.

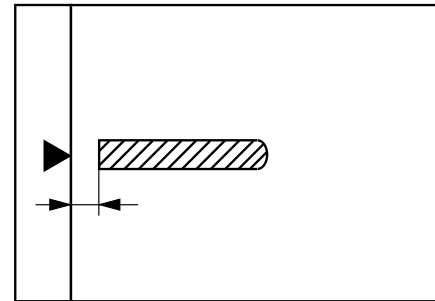

Note: Since the printed copy is used as a test chart, put the scale in parallel with the edge lines.

- 2) Make a copy, Then use the copy output as an original to make an SPF copy again.
- 3) Check the copy output. If necessary, perform the following adjustment procedures.
- 4) Execute SIM 50-1.
- 5) Set the SPF lead edge position set value (Exposure display <MANUAL> ON) so that the same image is obtained as that obtained in the previous OC image lead edge position adjustment.

<Adjustment specification>

Adjustment mode	SIM	LED	Set value	Spec value	Set range
SPF image lead edge position	SIM 50-1	MANUAL	1 step: 0.127mm shift	Lead edge void: 1 - 4mm Image loss: 3mm or less	1 ~ 99

c. Rear edge void adjustment

1) Set a scale as shown in the figure below.

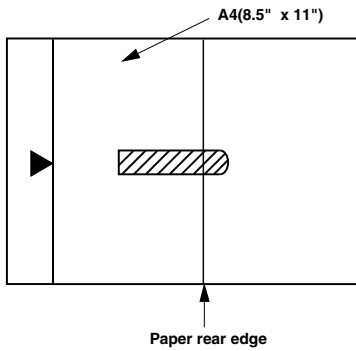

2) Set the document size to A4 (8.5" x 11"), and make a copy at 100%.

3) If necessary, perform the following adjustment procedure.

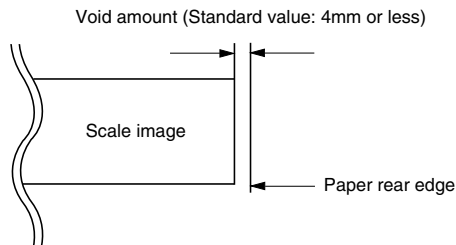

4) Execute SIM 50-1 and set the density mode to AUTO + PHOTO (Rear edge void).

The currently set adjustment value is displayed.

5) Enter the set value and press the start key.

The correction value is stored and a copy is made.

* 2nd print surface (auto duplex) rear edge void adjustment: Exposure display <EXP 5>

* Set to S → D mode before execution.

Note: Before performing the 2nd print surface rear edge void adjustment, be sure to perform the 2nd print surface lead edge position adjustment. Never reverse the sequence.

<Adjustment specification>

Mode	SIM	LED	Set value	Specification	Set range
Rear edge void	SIM 50-1	AUTO + PHOTO	1 step: 0.127mm shift	4mm or less	1 ~ 99
2nd print surface rear edge void	SIM 50-1*	EXP 5		4mm or less	

* Set to S → D mode before execution

d. Paper off center adjustment

1) Execute SIM 50-1 and set the density mode of AUTO + MANUAL (Left edge void) to 1.

2) Set a test chart (UKOG-0089SCZZ) on the document table.

3) Select a paper feed port and make a copy.

Compare the copy and the test chart. If necessary, perform the following adjustment procedure.

4) Execute SIM 50-10.

After completion of warmup, shading is performed and the currently set off center adjustment value of each paper feed port is displayed.

5) Enter the set value and press the start key.

The correction value is stored and a copy is made.

* 2nd print surface (auto duplex) off-center adjustment: Exposure display: None

<Adjustment specification>

Mode	SIM	LED	Set value	Specification	Set range
Paper off center	SIM 50-10	Selected tray ON	Add 1: 0.127mm shift to R side.	Single: Center ±2.0mm	1 ~ 99
2nd print surface off-center	SIM 50-10	No display	Reduce 1: 0.127mm shift to L side.	Duplex: Center ±2.5mm	

* When SIM 48-01 (AE) is executed, the document off-center is automatically set. Therefore, the off-center adjustment previously described in 5) must be adjusted again.

e. Left edge void area adjustment

Note: Before performing this adjustment, be sure to check that the paper off center adjustment (SIM 50-10) is completed.

1) Set a test chart (UKOG-0089SCZZ) on the document table.

2) Select a paper feed port and make two copies.

Compare the 2nd copy and the test chart. If necessary, perform the following adjustment procedure.

* The 1st copy does not show the void. Be sure to check the 2nd copy.

3) Execute SIM 50-1 and set the density mode to AUTO + MANUAL (Left edge void).

The currently set adjustment value is displayed.

(When the off center adjustment previously described is performed, "0" is displayed.)

4) Enter the set value and press the start key.

The correction value is stored and a copy is made.

<Adjustment specification>

Mode	SIM	LED	Set value	Specification	Set range
Left edge void	SIM 50-1	AUTO + MANUAL	1 step: 0.127mm shift	0.5 ~ 4mm	1 ~ 99

* When the left edge void is set with the paper off center adjusted, the both edge void is automatically adjusted.

(2) Main scanning direction (FR directional distortion balance adjustment)

1) Remove the OC glass and the right cabinet.

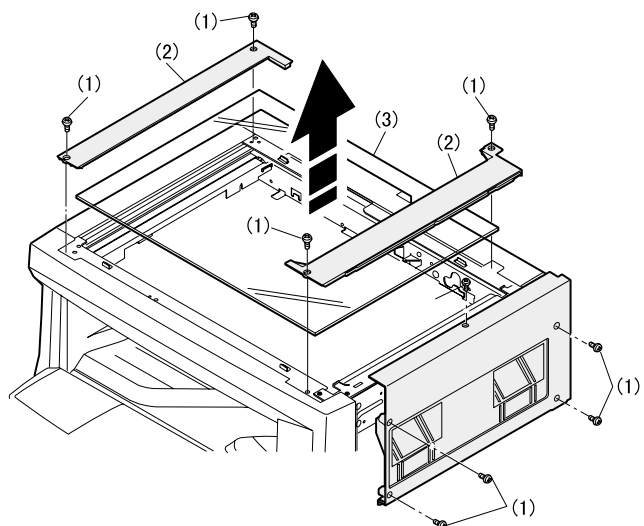

2) Loosen the copy lamp unit wire fixing screw.

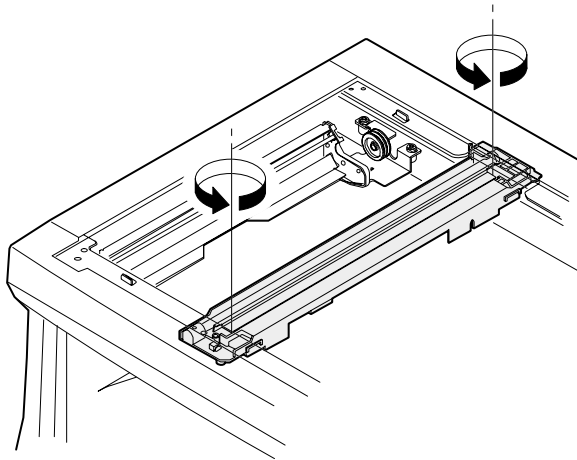
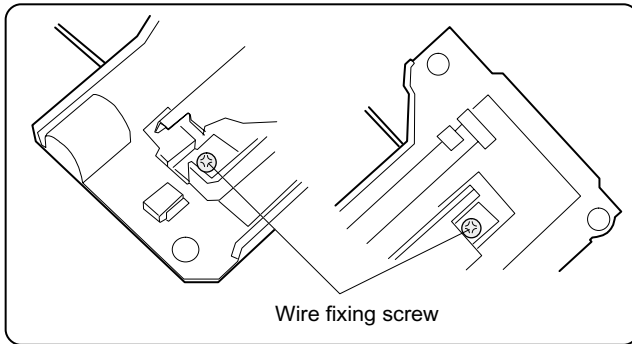

3) Manually turn the mirror base drive pulley and bring No. 2/3 mirror base unit into contact with the positioning plate.

At that time, if the front frame side and the rear frame side of No. 2/3 mirror base unit are brought into contact with the positioning plate at the same time, the mirror base unit parallelism is proper. If one of them is in contact with the positioning plate, perform the adjustment of 4).

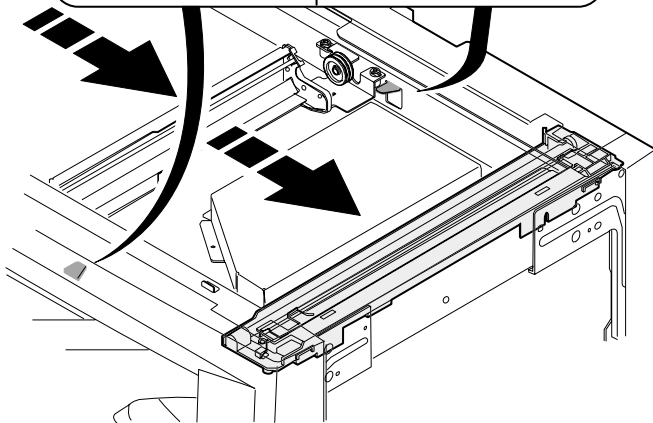
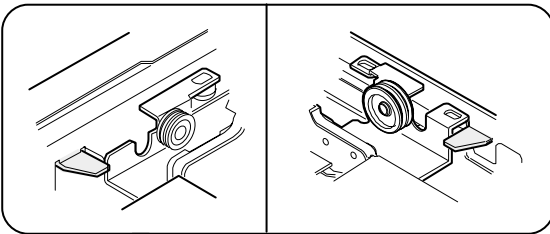

4) Loosen the set screw of the scanner drive pulley which is not in contact with No. 2/3 mirror base unit positioning plate.

5) Without moving the scanner drive pulley shaft, manually turn the scanner drive pulley until the positioning plate is brought into contact with No. 2/3 mirror base unit, then fix the scanner drive pulley.

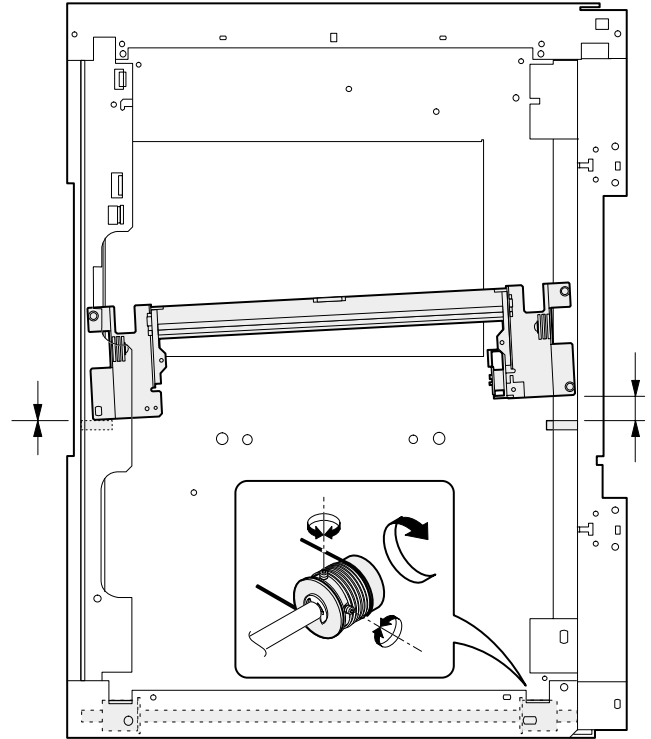

6) Put No. 2/3 mirror base unit on the positioning plate again, push the projections on the front frame side and the rear frame side of the copy lamp unit to the corner frame, and tighten the wire fixing screw.

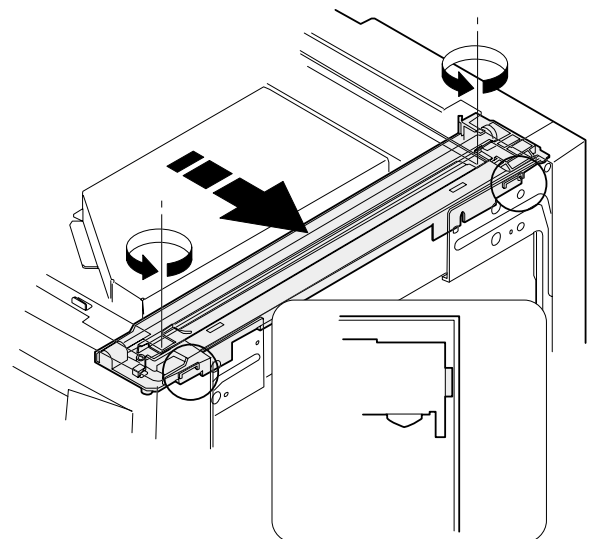
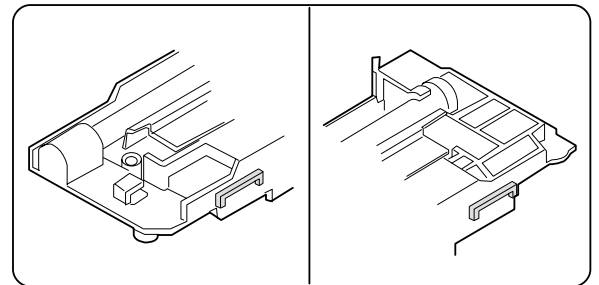

(3) Main scanning direction (FR direction) distortion adjustment

This adjustment must be performed in the following cases:

- When the mirror base drive wire is replaced.
- When the lamp unit, or No. 2/3 mirror holder is replaced.
- When a copy as shown is made.

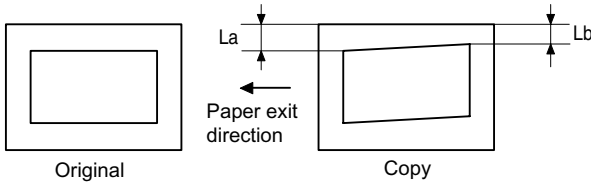

- 1) Set A3 (11" x 17") white paper on the original table as shown below.

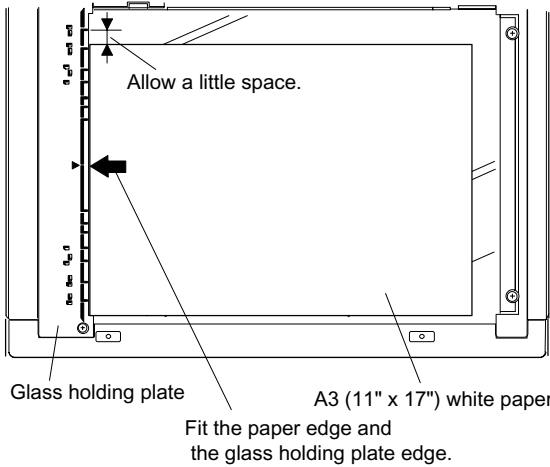

- 2) Open the original cover and make a normal (100%) copy.
- 3) Measure the width of the black background at the lead edge and at the rear edge.

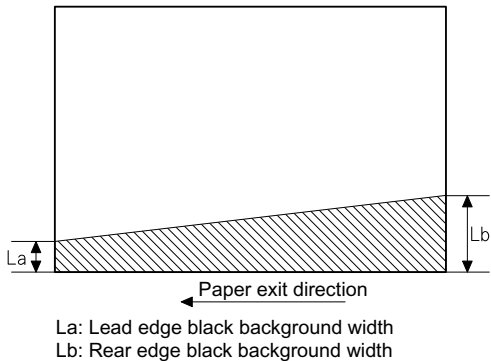

If the width (La) of the black background at the lead edge is equal that (Lb) at the rear edge, there is no need to execute the following procedures of 4) ~ 7).

- 4) Loosen the mirror base drive pulley fixing screw on the front frame side or on the rear frame side.

- When $L_a < L_b$
Turn the mirror base drive pulley on the front frame side in the arrow direction A. (Do not move the mirror base drive pulley shaft.)
- When $L_a > L_b$
Turn the mirror base drive pulley on the front frame side in the arrow direction A. (Do not move the mirror base drive pulley shaft.)

- 5) Tighten the mirror base drive pulley fixing screw.

<Adjustment specification>

$L_a = L_b$

- 6) Execute the main scanning direction (FR) distortion balance adjustment previously described in 2) again.

(4) Sub scanning direction (scanning direction) distortion adjustment

When there is no skew copy in the mirror base scanning direction and there is no horizontal error (right angle to the scanning direction), the adjustment can be made by adjusting the No. 2/3 mirror base unit rail height.

Before performing this adjustment, be sure to perform the horizontal image distortion adjustment in the laser scanner section.

This adjustment must be performed in the following cases:

- When the mirror base wire is replaced.
- When the copy lamp unit or No. 2/3 mirror unit is replaced.
- When the mirror unit rail is replaced or moved.
- When a following copy is made.

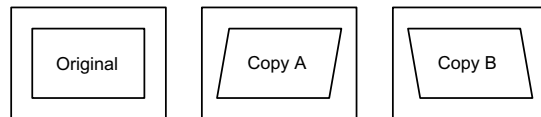

1) Making of a test sheet

Make test sheet by drawing parallel lines at 10mm from the both ends of A3 (11" x 17") white paper as shown below. (These lines must be correctly parallel to each other.)

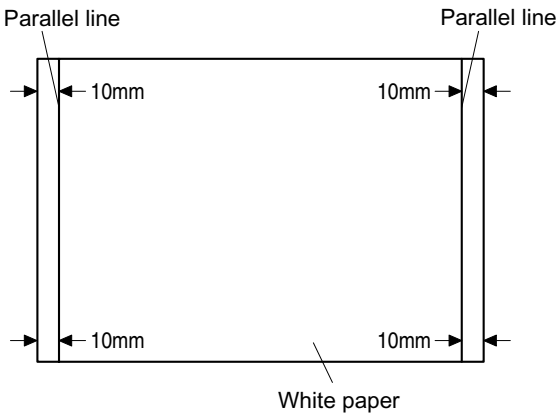

- 2) Make a normal (100%) copy of the test sheet on A3 (11" x 17") paper. (Fit the paper edge with the glass holding plate edge.)
- 3) Measure the distances (La, Lb, Lc, Ld) at the four corners as shown below.

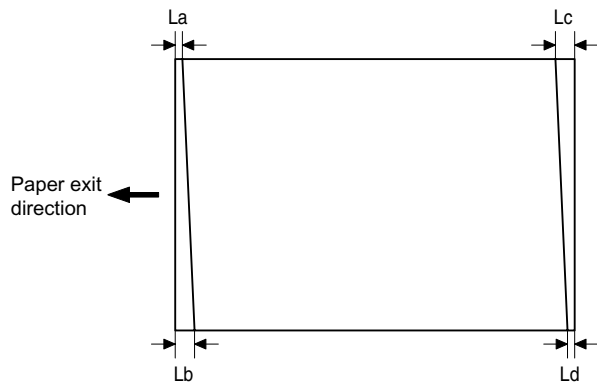

When $L_a = L_b$ and $L_c = L_d$, no need to perform the procedures 4) and 5).

- 4) Move the mirror base F rail position up and down (in the arrow direction) to adjust.

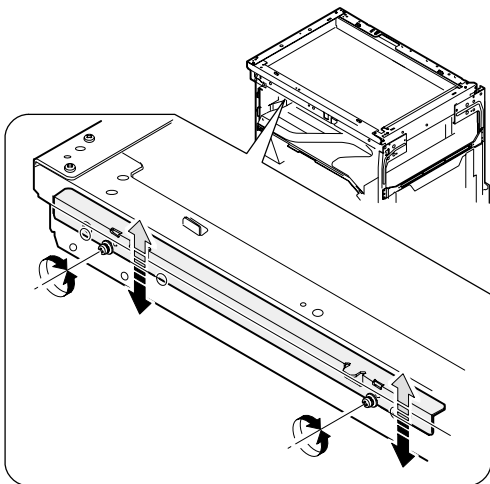

(Note) If the rear side rail is used for the adjustment, the scanning position of the white balance sheet is shifted and "E7-04" may occur only when scanning with the SPF. Therefore it is advisable to use the front side rail for the adjustment.

- When $L_a > L_b$
Shift the mirror base B rail upward by the half of the difference of $L_a - L_b$.
- When $L_a < L_b$
Shift the mirror base B rail downward by the half of the difference of $L_b - L_a$.
Example: When $L_a = 12\text{mm}$ and $L_b = 9\text{mm}$, shift the mirror base B rail upward by 1.5mm.
- When $L_c > L_d$
Shift the mirror base B rail downward by the half of the difference of $L_c - L_d$.
- When $L_c < L_d$
Shift the mirror base B rail downward by the half of the difference of $L_d - L_c$.
- * When moving the mirror base rail, hold the mirror base rail with your hand.

<Adjustment specification>

$L_a = L_b, L_c = L_d$

- 5) After completion of adjustment, manually turn the mirror base drive pulley, scan the mirror base A and mirror base B fully, and check that the mirror bases are not in contact with each other.
- * If the mirror base rail is moved extremely, the mirror base may be in contact with the frame or the original glass. Be careful to avoid this.

(5) Main scanning direction (FR direction) magnification ratio adjustment (SIM 48-1)

Note: Before performing this adjustment, be sure to check that the CCD unit is properly installed.

- 1) Put a scale on the original table as shown below.

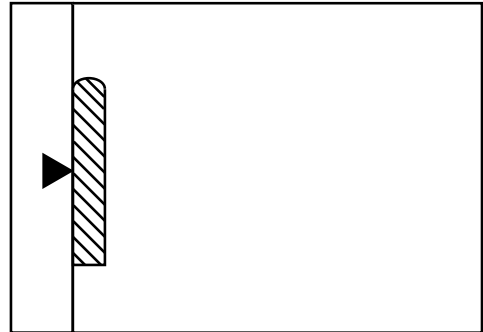

- 2) Execute SIM 48-1.
- 3) After warmup, shading is performed and the current set value of the main scanning direction magnification ratio is displayed on the display section in 2 digits.
- 4) Select the mode and press the start key again.
- 5) Auto correction mode (AE lamp ON)
The mirror unit moves to the shading position, and the reference width of the reference white plate is scanned, and the correction value is automatically calculated from that scanned value.
The correction value is displayed and a copy is made.
- 6) Compare the scale image and the actual scale.
If a fine adjustment is required, switch to the manual correction mode with the magnification ratio display key and perform fine adjustment.
- 7) Manual correction mode (TEXT lamp ON)
Enter the set value and press the start key.
The set value is stored and a copy is made.

<Adjustment specification>

Note: A judgement must be made with 200mm width, and must not be made with 100mm width.

Mode	Specification	SIM	Set value	Set range
Main scanning direction magnification ratio	At normal: $\pm 1.0\%$	SIM 48-1	Add 1: 0.1% increase Reduce 1: 0.1% decrease	1 ~ 99

- Error in the auto correction mode

Display	Content	Major cause
Copy quantity display "-- --"	The correction value calculated is over 5%.	<ul style="list-style-type: none"> • Improper position of reference width line of the reference white plate • Improper installation of CCD unit
Paper jam lamp ON	Reference line scanning error	<ul style="list-style-type: none"> • Defective CCD • No reference white plate

* When SIM 48-01 (AE) is executed, the main scanning direction magnification ratio is automatically set. Therefore, the main scanning direction magnification ratio adjustment previously described in 5) must be made again.

(6) Sub scanning direction (scanning direction) magnification ratio adjustment (SIM 48-2, SIM 48-5)

a. OC mode in copying

Note: • Before performing this adjustment, be sure to check that the CCD unit is properly installed.

- 1) Put a scale on the original table as shown below, and make a normal (100%) copy.
- 2) Compare the scale image and the actual image. If necessary, perform the following adjustment procedures.
- 3) Execute SIM 48-2.
- 4) After warmup, shading is performed and the current set value of the sub scanning direction magnification ratio is displayed on the display section in 2 digits.
- 5) Enter the set value and press the start key.
The set value is stored and a copy is made.

<Adjustment specification>

Mode	Specification	SIM	Set value	Set range
Sub scanning direction magnification ratio (OC mode)	Normal $\pm 1.0\%$	SIM 48-2	Add 1: 0.1% increase Reduce 1: 0.1% decrease	1 ~ 99

b. RSPF sub scanning direction magnification ratio

Note: • Before performing this adjustment, be sure to check that the CCD unit is properly installed.

- Before performing this adjustment, the OC mode adjustment in copying must be completed.

- 1) Put a scale on the original table as shown below, and make a normal (100%) copy to make a test chart.

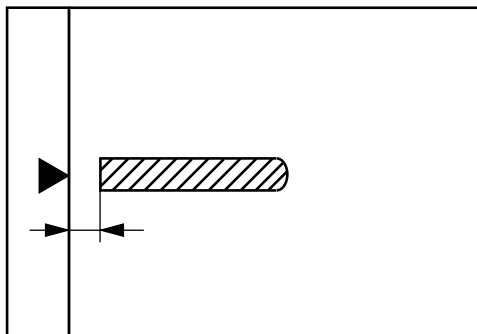

Note: Since the printed copy is used as a test chart, put the scale in parallel with the edge lines.

- 2) Set the test chart on the SPF and make a normal (100%) copy.
- 3) Compare the scale image and the actual image. If necessary, perform the following adjustment procedures.
- 4) Execute SIM 48-5.
- 5) After warmup, shading is performed.
The auto density lamp lights up and the current front surface sub scanning direction magnification ratio correction value is displayed in two digits on the display section.
- 6) Enter the set value and press the start key.
The set value is stored and a copy is made.
- 7) Change the mode from the duplex original mode to the simplex original mode.
"MANUAL" lamp lights up and the current back surface sub scanning direction magnification ratio is displayed in two digits on the display section.
- 8) Enter the set value and press the start key.
The set value is stored and a copy is made.

<Adjustment specification>

Mode	Specification	SIM	Set value	Set range
Sub scanning direction magnification ratio (SPF mode)	Normal $\pm 1.0\%$	SIM 48-5	Add 1: 0.1% increase Reduce 1: 0.1% decrease	1 ~ 99

(7) Off center adjustment (SIM 50-13, SIM 50-16)

a. OC mode

Note: • The operation of SIM 50-13 is the same as that of SIM 48-01 (Photo LED ON)

- 1) Make a test chart as shown below and set it so that its center line is fit with the original guide center mark.
* To make a test chart, draw a line on A3 or 11" x 17" paper at the center in the paper transport direction.

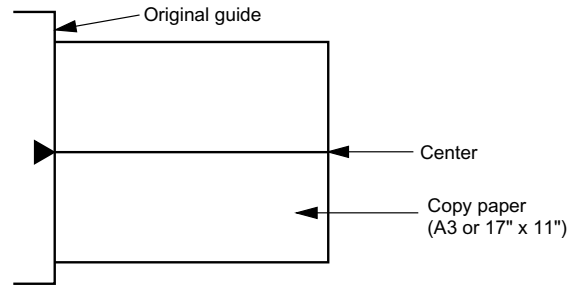

- 2) Make a normal copy from the manual paper feed tray, and compare the copy and the test chart.
If necessary, perform the following adjustment procedures.
- 3) Execute SIM 50-13.
- 4) After warmup, shading is performed and the current set value of the off center adjustment is displayed on the display section in 2 digits.
- 5) Enter the set value and press the start key.
The set value is stored and a copy is made.

<Adjustment specification>

Mode	Specification	SIM	Set value	Set range
Original off center mode (OC mode)	Single: Center $\pm 2.0\text{mm}$	SIM 50-13	Add 1: 0.1mm shift to R side Reduce 1: 0.1mm shift to L side	1 ~ 99
	Duplex: Center $\pm 2.5\text{mm}$			

b. SPF original off-center adjustment

Note: • Before performing this adjustment, be sure to check that the paper off center is properly adjusted.

- 1) Make a test chart for the center position adjustment and set it on the SPF.

<Adjustment specification>

Draw a line on a paper in the scanning direction.

- 2) Make a normal copy from the manual paper feed tray, and compare the copy and the original test chart.
If necessary, perform the following adjustment procedures.
- 3) Execute SIM 50-16.
- 4) After warmup, shading is performed and the current set value of the off center adjustment at each paper feed port is displayed on the display section in 2 digits.
- 5) Enter the set value and press the start key.
The set value is stored and a copy is made.

<Adjustment specification>

Mode	Specification	SIM	Set value	Set range
Original off center mode (SPF mode)	Single: Center ± 3.0mm	SIM 50-16	Add 1: 0.1mm shift to R side	1 ~ 99
	Duplex: Center ±3.5mm		Reduce 1: 0.1mm shift to L side	

(8) OC (SPF) open/close detection position adjustment

- 1) Set A4 or 8 1/2" x 11" paper on the OC table.
Check that the document size display on the operation panel indicates the correct size of the set paper.
- 2) Close the OC (SPF) with a small clearance for insertion of your hand left, and remove the paper from the OC table.
The document size display does not change from the display in 1).
- 3) Open the OC (SPF) slowly until the display on the operation panel changes (all the document size display lamps are turned off), and measure dimension A shown below under that state.

Distance A = Table glass top - OC (SPF) knob 117"

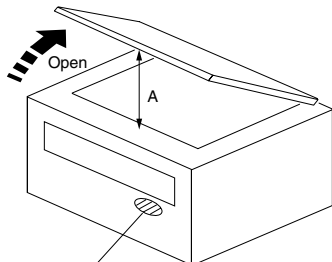

Check the position where the display checked in procedure 1) is changed.

<Spec value>

OC (SPF) open/close position A: 207 ~ 302mm

- 4) If the OC (SPF) open/close position A is not 207 ~ 302mm, adjust the open/close sensor mounting plate position as shown below.

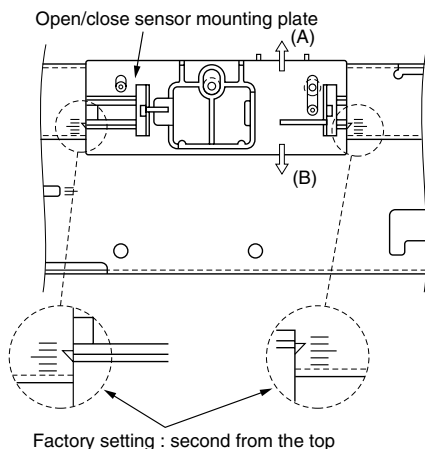

Factory setting : second from the top

**(9) Original sensor adjustment (SIM 41-3)
<Other than AR-162/163>**

- 1) Execute SIM 41-2.
- 2) Set A3 (11" x 17") paper on the OC table.
- 3) Press the start key again.
- 4) The sensor level of the original sensor is automatically checked and the value with an original - 40 is made as the threshold value for scanning. (Automatic setting)
- 5) Execute SIM 41-3.
- 6) The light reception level of the original sensor is displayed. (The mode selection is made with the magnification ratio display key.)
The 1st digit of the copy quantity display shows "A": Light reception level display
The 1st digit of the copy quantity display shows "b": Original judgement level display
- 7) By changing the paper set on the original table, the original size LED sensed by the sensor is lighted.

C. Image density adjustment

(1) Copy mode (SIM 46-1)

- 1) Set a test chart (UKOG-0162FCZZ) on the OC table as shown below.

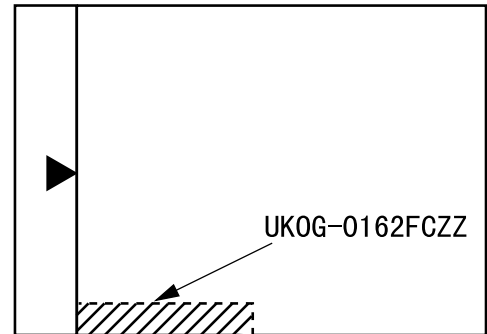

- 2) Put several sheets of A3 or 11" x 17" white paper on the test chart.
- 3) Execute SIM 46-1.
- 4) After warmup, shading is performed and the current set value of the density level is displayed on the display section in 2 digits.
For mode selection, use the density select key.
- 5) Change the set value with the 10-key to adjust the copy image density.
- 6) Make a copy and check that the specification below is satisfied.

<Adjustment specification>

Density mode	Display lamp	Exposure level	Sharp Gray Chart output	Set value	Set range
Auto	Auto	—	"3" is slightly copied.	The greater the set value is, the greater the density is. The smaller the set value is, the smaller the density is.	1 ~ 99
Manual	Manual	3	"3" is slightly copied.		
Photo	Photo	3	"3" is slightly copied.		
Toner save	Manual/Photo	3	"3" is slightly copied.		

[7] SIMULATIONS

1. Entering the simulation mode

Perform the following procedure to enter the simulation mode.
 Clear key → Interrupt key → "0" key → Interrupt key → Main code →
 Start key → Sub code → Start key

2. Cancelling the simulation mode

When the clear all key is pressed, the simulation mode is cancelled.
 When the interruption key is pressed, the process is interrupted and the screen returns to the sub code entering display.

* After canceling the simulation mode, be sure to turn OFF/ON the power and check the operation.

3. List of simulations

Main code	Sub code	Contents	*
1	1	Mirror unit operation check	
	2	Optical system sensor operation check	
2	1	SPF aging	ADF
	2	SPF sensor operation check	ADF
	3	SPF motor forward rotation operation check	ADF
	4	SPF motor reverse rotation operation check	ADF
	8	SPF paper feed solenoid operation check	ADF
	9	RSPF reverse solenoid operation check	AD
3	10	RSPF paper exit gate solenoid operation check	AD
	11	SPF PS release solenoid operation check	ADF
	2	Shifter job separator sensor operation check	AEF
	3	Shifter operation check	E
	4	Job separator operation check	AF
5	11	Shifter Home Position Check	E
	1	Operation panel display check	
	2	Heater lamp lighting check, cooling fan motor operation check	
	3	Copy lamp lighting check	
6	1	Paper feed solenoid operation check	
	10	Main cassette semi-circular roller drive	
7	1	Aging with warmup time display	
	4	Warmup saving	
	6	Intermittent aging	
	8	Warmup time display	
9	1	Duplex motor forward rotation operation check	B
	2	Duplex motor reverse rotation operation check	B
	4	Duplex motor rotation speed adjustment	B
	5	Duplex motor switchback time adjustment	B
10		Toner motor operation check	
14		Trouble (except for U2) cancel	
16		U2 trouble cancel	
20	1	Maintenance counter clear	
21	1	Maintenance cycle setting	
	2	Mini maintenance cycle setting	
22	1	Maintenance counter display	
	2	Maintenance preset value display	
	3	JAM memory display	
	4	Total JAM counter display	
	5	Total counter display	
	6	Developing counter display	
	7	Developing preset counter value display	
	8	SPF counter display	ADF
	9	Paper feed counter display	
	12	Drum counter display	
	14	Copier ROM version display	

Main code	Sub code	Contents	*	
22	15	Trouble memory display		
	16	Duplex print counter display	B	
	17	Copy counter display		
	18	Printer counter display	A	
	19	Electronic sort counter display	AD	
	21	Scanner counter display		
24	1	JAM memory, JAM counter clear		
	2	Trouble memory clear		
	4	SPF counter clear	ADF	
	5	Duplex counter clear	B	
	6	Paper feed counter clear		
	7	Drum counter clear		
	8	Copy counter clear		
	9	Printer counter clear	A	
	10	Electronic sort counter clear	AD	
	13	Scanner counter clear		
	25	1	Main motor operation check	
		10	Polygon motor operation check	
	26	1	Option switch display	
3		Auditor setting		
5		Counter mode setting		
6		Destination setting		
7		CRUM set value display		
10		Model name setting		
22		Language setting		
30		CE mark conformity control setting		
32		Fan rotation duty change state setup		
37		Cancel of stop at developer life over		
38		Cancel of stop at dram life over		
42		Transfer timing adjustment		
50		Black-white reversion function setup		
51		Sort/Group copy temporary stop function setup	AD	
30		1	Machine sensor operation check	
41		2	OC document sensor adjustment	C
		3	Document sensor light reception level display	C
42		1	Developing counter clear	
43		1	Fusing temperature setting	
46		1	Copy density level adjustment	
		19	AE mode picture quality change	
48	1	Main scanning (front/rear) direction magnification ratio adjustment (Copy/FAX/OC-SPF common)		
	2	OC mode sub scanning direction magnification ratio adjustment in copying		
	5	SPF mode sub scanning direction magnification ratio adjustment in copying	D	
50	1	Copy image lead edge position adjustment		
	10	Paper off center adjustment		
	13	OC mode document off center adjustment		
	16	SPF mode document off center adjustment	D	
	18	Duplex memory reverse print adjustment	B	
51	19	Duplex rear edge void adjustment	B	
	2	Resist amount adjustment		
63	1	Shading data check		
64	1	Self printing mode		
67	14	Printer Flash ROM Data Download	A	

*A: Only when an option is installed.

B: AR-206/207 only

C: Other than AR162/163

D: AR-207 only

E: Other than AR-162

F: AR-F201 only

4. Contents of simulations

Main code	Sub code	Contents	Details of operation	Initial value	Set range				
1	1	Mirror unit operation check	Used to execute scanning at the speed corresponding to the set magnification ratio. <table border="1"> <thead> <tr> <th>Key operation</th> <th>Display</th> </tr> </thead> <tbody> <tr> <td>Changing the magnification ratio: Fixed magnification ratio key ZOOM UP KEY, ZOOM DOWN KEY</td> <td>Set magnification ratio: Fixed magnification ratio LED ZOOM LED</td> </tr> </tbody> </table>	Key operation	Display	Changing the magnification ratio: Fixed magnification ratio key ZOOM UP KEY, ZOOM DOWN KEY	Set magnification ratio: Fixed magnification ratio LED ZOOM LED	100%	50 ~ 200%
	Key operation	Display							
Changing the magnification ratio: Fixed magnification ratio key ZOOM UP KEY, ZOOM DOWN KEY	Set magnification ratio: Fixed magnification ratio LED ZOOM LED								
2	Optical system sensor operation check	Used to check MHPS (Mirror home position sensor) ON/OFF state with the LED on the operation panel. <table border="1"> <thead> <tr> <th>Display</th> </tr> </thead> <tbody> <tr> <td><Lighting when the sensor is ON> MHPS: Paper empty LED</td> </tr> </tbody> </table>	Display	<Lighting when the sensor is ON> MHPS: Paper empty LED					
Display									
<Lighting when the sensor is ON> MHPS: Paper empty LED									
2	1	SPF aging <Only when an SPF/RSPF is installed>	Used to perform SPF document transport. The paper size is not detected. (Excluding postcards, extra large sheet of 1m or greater.) With SPF installed: Single transport operation With RSPF installed: Duplex transport operation <table border="1"> <thead> <tr> <th>Key operation</th> <th>Display</th> </tr> </thead> <tbody> <tr> <td>Changing the magnification ratio: Fixed magnification ratio key ZOOM UP KEY, ZOOM DOWN KEY</td> <td>Set magnification ratio: Fixed magnification ratio LED ZOOM LED</td> </tr> </tbody> </table>	Key operation	Display	Changing the magnification ratio: Fixed magnification ratio key ZOOM UP KEY, ZOOM DOWN KEY	Set magnification ratio: Fixed magnification ratio LED ZOOM LED	100%	50 ~ 200%
	Key operation	Display							
	Changing the magnification ratio: Fixed magnification ratio key ZOOM UP KEY, ZOOM DOWN KEY	Set magnification ratio: Fixed magnification ratio LED ZOOM LED							
	2	SPF sensor operation check <Only when an SPF/RSPF is installed>	Used to check sensors in SPF with the LED on the operation panel. <table border="1"> <thead> <tr> <th>Display</th> </tr> </thead> <tbody> <tr> <td><Lighting at sensor ON> PW1: JAM LED PW2: Paper empty LED PW3: Machine position JAM LED PW4: SPF JAM LED PL1: Manual paper feed tray select LED PL2: 2nd tray position JAM LED P-IN: SPF select LED SPF COVER OPEN: Main cassette select LED</td> </tr> </tbody> </table>	Display	<Lighting at sensor ON> PW1: JAM LED PW2: Paper empty LED PW3: Machine position JAM LED PW4: SPF JAM LED PL1: Manual paper feed tray select LED PL2: 2nd tray position JAM LED P-IN: SPF select LED SPF COVER OPEN: Main cassette select LED				
	Display								
	<Lighting at sensor ON> PW1: JAM LED PW2: Paper empty LED PW3: Machine position JAM LED PW4: SPF JAM LED PL1: Manual paper feed tray select LED PL2: 2nd tray position JAM LED P-IN: SPF select LED SPF COVER OPEN: Main cassette select LED								
	3	SPF motor forward rotation operation check <Only when an SPF/RSPF is installed>	Used to rotate the SPF motor forward for 10 sec.						
	4	SPF motor reverse rotation operation check <Only when an SPF/RSPF is installed>	Used to rotate the SPF motor reversely for 10 sec.						
	8	SPF paper feed solenoid operation check <Only when an SPF/RSPF is installed>	Used to drive the SPF paper feed solenoid (PSOL) at the cycle of 500 msec ON and 500 msec OFF 20 times.						
	9	RSPF reverse solenoid operation check <Only when an RSPF is installed>	Used to drive the RSPF reverse solenoid (RSOL) at the cycle of 500 msec ON and 500 msec OFF 20 times.						
	10	RSPF paper exit gate solenoid operation check <Only when an RSPF is installed>	Used to drive the RSPF paper exit gate solenoid (GSOL) at the cycle of 500 msec ON and 500 msec OFF 20 times.						
11	SPF PS release solenoid operation check <Only when an SPF/RSPF is installed>	Used to drive the SPF PS release solenoid at the cycle of 500 msec ON and 500 msec OFF 20 times.							

Main code	Sub code	Contents	Details of operation	Initial value	Set range				
3	2	Shifter job separator sensor operation check <Only when a job separator shifter>	Used to check the sensors state in the shifter job separator with the LED on the operation panel. <table border="1" style="width: 100%;"> <tr><td style="text-align: center;">Display</td></tr> <tr><td><Lighting at sensor ON> Shifter HP sensor: Machine position JAM LED Job separator HP sensor: SPF JAM LED Paper exit full sensor: 2nd tray position JAM LED</td></tr> </table>	Display	<Lighting at sensor ON> Shifter HP sensor: Machine position JAM LED Job separator HP sensor: SPF JAM LED Paper exit full sensor: 2nd tray position JAM LED				
	Display								
	<Lighting at sensor ON> Shifter HP sensor: Machine position JAM LED Job separator HP sensor: SPF JAM LED Paper exit full sensor: 2nd tray position JAM LED								
	3	Shifter operation check <Only when an shifter is installed>	Used to drive the shifter motor at the speed of printing of A4 (8-1/2 × 11"). Pressing the clear all key or interrupt key moves the shifter to the home position. <table border="1" style="width: 100%;"> <tr><td style="text-align: center;">Key operation</td></tr> <tr><td>The shifter is moved to the home position: Clear all key, interrupt key</td></tr> </table>	Key operation	The shifter is moved to the home position: Clear all key, interrupt key				
Key operation									
The shifter is moved to the home position: Clear all key, interrupt key									
4	Job separator operation check <Only when an Job separator is installed>	Used to drive the job separator one way. Pressing the clear all key or interrupt key stops the job separator at the home position. <table border="1" style="width: 100%;"> <tr><td style="text-align: center;">Key operation</td></tr> <tr><td>Stops at the home position: Clear all key, interrupt key</td></tr> </table>	Key operation	Stops at the home position: Clear all key, interrupt key					
Key operation									
Stops at the home position: Clear all key, interrupt key									
11	Shifter Home Position check <Only when a sifter is installed>	Used to drive the shifter motor <table border="1" style="width: 100%;"> <tr><td style="text-align: center;">Key operation</td></tr> <tr><td>Feed: Exposure up key or "3" key Return: Exposure down key or "4" key Move to Home Position: Magnification ratio display key or "5" key</td></tr> </table>	Key operation	Feed: Exposure up key or "3" key Return: Exposure down key or "4" key Move to Home Position: Magnification ratio display key or "5" key					
Key operation									
Feed: Exposure up key or "3" key Return: Exposure down key or "4" key Move to Home Position: Magnification ratio display key or "5" key									
5	1	Operation panel display check	Used to light all LED's on the operation panel for 5 sec.						
	2	Heater lamp lighting check, cooling fan motor operation check	Used to turn ON the heater lamp for 500 msec and OFF for 500 msec 5 times. At the same time, the cooling fan is rotated at a high speed. After checking the heater lamp operation, the cooling fan motor rotate at a low speed.						
	3	Copy lamp lighting check	Used to light the copy lamp for 10 sec.						
6	1	Paper feed solenoid operation check	When the start key is pressed, the selected paper feed solenoid is driven at the cycle of 500 msec ON and 500 msec OFF 20 times. <table border="1" style="width: 100%;"> <thead> <tr> <th style="width: 50%;">Key operation</th> <th style="width: 50%;">Display</th> </tr> </thead> <tbody> <tr> <td>Solenoid selection: Tray select button</td> <td><Lighting at solenoid selection> Main cassette paper feed solenoid: Main cassette select LED Multi manual paper feed solenoid: Manual paper feed select LED No. 2 cassette paper feed solenoid: No. 2 cassette select LED No. 3 cassette paper feed solenoid: No. 3 cassette select LED <Only when an option is installed> No. 4 cassette paper feed solenoid: No. 4 cassette select LED <Only when an option is installed> Resist roller solenoid: Machine position JAM LED No. 2 cassette transport solenoid: No. 2 cassette position JAM LED No. 3 cassette transport solenoid: Machine position JAM LED + No. 2 cassette position JAM LED <Only when an option is installed> No. 4 cassette transport solenoid: JAM LED <Only when an option is installed></td> </tr> </tbody> </table>	Key operation	Display	Solenoid selection: Tray select button	<Lighting at solenoid selection> Main cassette paper feed solenoid: Main cassette select LED Multi manual paper feed solenoid: Manual paper feed select LED No. 2 cassette paper feed solenoid: No. 2 cassette select LED No. 3 cassette paper feed solenoid: No. 3 cassette select LED <Only when an option is installed> No. 4 cassette paper feed solenoid: No. 4 cassette select LED <Only when an option is installed> Resist roller solenoid: Machine position JAM LED No. 2 cassette transport solenoid: No. 2 cassette position JAM LED No. 3 cassette transport solenoid: Machine position JAM LED + No. 2 cassette position JAM LED <Only when an option is installed> No. 4 cassette transport solenoid: JAM LED <Only when an option is installed>		
	Key operation	Display							
Solenoid selection: Tray select button	<Lighting at solenoid selection> Main cassette paper feed solenoid: Main cassette select LED Multi manual paper feed solenoid: Manual paper feed select LED No. 2 cassette paper feed solenoid: No. 2 cassette select LED No. 3 cassette paper feed solenoid: No. 3 cassette select LED <Only when an option is installed> No. 4 cassette paper feed solenoid: No. 4 cassette select LED <Only when an option is installed> Resist roller solenoid: Machine position JAM LED No. 2 cassette transport solenoid: No. 2 cassette position JAM LED No. 3 cassette transport solenoid: Machine position JAM LED + No. 2 cassette position JAM LED <Only when an option is installed> No. 4 cassette transport solenoid: JAM LED <Only when an option is installed>								
10	Main cassette semi-circular roller drive	Excute the simulation with the developer cartridge removed, used to rotate the semi-circular roller of the main cassette one turn to face it downward.							

Main code	Sub code	Contents	Details of operation	Initial value	Set range										
7	1	Aging with warmup time display	Execute the simulation input with the copier side cover open, then close the side cover, and the machine will start warming up. Warm up time is counted up every 2nd and it is displayed. After completion of warmup, count up is terminated. When the clear all key is pressed ready lamp is lighted and the copy quantity is entered and the start key is pressed, copying is made to make the set quantity of copies. At that time, the paper size does not matter. <table border="1" style="width: 100%; text-align: center;"> <tr><td>Key operation</td></tr> <tr><td>Copy quantity setting: Copy quantity keys</td></tr> </table>	Key operation	Copy quantity setting: Copy quantity keys		1 ~ 99								
	Key operation														
	Copy quantity setting: Copy quantity keys														
	4	Warmup saving	Used to bring the machine to the ready state without warmup.		1 ~ 99										
6	Intermittent aging	After completion of warmup, counting is stopped and the ready lamp is lighted. When the copy quantity is entered and the start key is pressed, copying is made to make the set quantity of copies. After 3 sec standby, copying is made again to make the set quantity of copies. After that this operation is repeated. The paper size does not matter. <table border="1" style="width: 100%; text-align: center;"> <tr><td>Key operation</td></tr> <tr><td>Copy quantity setting: Copy quantity keys</td></tr> </table>	Key operation	Copy quantity setting: Copy quantity keys		1 ~ 99									
Key operation															
Copy quantity setting: Copy quantity keys															
8	Warmup time display	Execute the simulation input with the copier side cover open, then close the side cover, and the machine will starts warming up. Warm up time is counted up every 2nd and it is displayed.		1 ~ 99											
9	1	Duplex motor forward rotation operation check <Only AR-206/207>	Used to rotate the duplex motor forward for 30 sec.												
	2	Duplex motor reverse rotation operation check <Only AR-206/207>	Used to rotate the duplex motor reversely for 30 sec.												
	4	Duplex motor rotation speed adjustment <Only AR-206/207>	The currently set duplex motor rotation speed set value is displayed. When the set value is entered and the start key is pressed, the set value is stored. <table border="1" style="width: 100%; text-align: center;"> <tr><td>Key operation</td></tr> <tr><td>Duplex motor rotation speed set value: Copy quantity keys</td></tr> </table>	Key operation	Duplex motor rotation speed set value: Copy quantity keys	6	1 ~ 13								
	Key operation														
Duplex motor rotation speed set value: Copy quantity keys															
5	Duplex motor switchback time adjustment <Only AR-206/207>	The currently set duplex motor switchback time set value is displayed. When the set value is entered and the start key is pressed, the set value is stored. <table border="1" style="width: 100%; text-align: center;"> <tr><td>Key operation</td></tr> <tr><td>Duplex motor switchback time set value: Copy quantity keys</td></tr> </table>	Key operation	Duplex motor switchback time set value: Copy quantity keys	50	18 ~ 76									
Key operation															
Duplex motor switchback time set value: Copy quantity keys															
10		Toner motor operation check	Used to operate the toner motor for 30 sec. Note: If this simulation is executed with the toner hopper installed, toner is automatically supplied to the developer. Be careful of overtoner.												
14		Trouble (except for U2) cancel	Used to cancel troubles except for U2.												
16		U2 trouble cancel	Used to cancel U2 trouble.												
20	1	Maintenance counter clear	Used to clear the maintenance counter. *2												
21	1	Maintenance cycle setting	Used to display the currently set maintenance cycle at the numbers shown at right. When the set value is entered and the start key is pressed, the set value is stored. <table border="1" style="width: 100%; text-align: center;"> <tr><td colspan="2">Key operation/Display</td></tr> <tr><td>0: 2500 sheets</td><td>4: 150000 sheets</td></tr> <tr><td>1: 5000 sheets</td><td>5: FREE (999999 sheets)</td></tr> <tr><td>2: 15000 sheets</td><td>6: 10000 sheets</td></tr> <tr><td>3: 30000 sheets</td><td>7: 7500 sheets</td></tr> </table>	Key operation/Display		0: 2500 sheets	4: 150000 sheets	1: 5000 sheets	5: FREE (999999 sheets)	2: 15000 sheets	6: 10000 sheets	3: 30000 sheets	7: 7500 sheets	4	0 ~ 6
Key operation/Display															
0: 2500 sheets	4: 150000 sheets														
1: 5000 sheets	5: FREE (999999 sheets)														
2: 15000 sheets	6: 10000 sheets														
3: 30000 sheets	7: 7500 sheets														

*2: Display after clearing each counter
000 (0.75 sec) → Blank (0.35 sec) → 000 (0.75 sec) → Blank (1.0 sec) → Repetition

Main code	Sub code	Contents	Details of operation	Initial value	Set range										
21	2	Mini maintenance cycle setting <Japan only>	Used to display the currently set mini maintenance cycle at the numbers shown at right. When the set value is entered and the start key is pressed, the set value is stored. <table border="1"> <thead> <tr> <th colspan="2">Key operation/Display</th> </tr> </thead> <tbody> <tr> <td>0: 2500 sheets</td> <td>4: 30000 sheets</td> </tr> <tr> <td>1: 5000 sheets</td> <td></td> </tr> <tr> <td>2: 10000 sheets</td> <td></td> </tr> <tr> <td>3: FREE (999999 sheets)</td> <td></td> </tr> </tbody> </table>	Key operation/Display		0: 2500 sheets	4: 30000 sheets	1: 5000 sheets		2: 10000 sheets		3: FREE (999999 sheets)		4	
Key operation/Display															
0: 2500 sheets	4: 30000 sheets														
1: 5000 sheets															
2: 10000 sheets															
3: FREE (999999 sheets)															
22	1	Maintenance counter display	Used to display the current maintenance counter value. *1												
	2	Maintenance preset value display	Used to display the current maintenance preset value (set with SIM 21-1). *1												
	3	JAM memory display	Used to display a JAM generated during copying on the JAM position display on the operation panel. Max. 30 recent jams are stored. JAM No. 1 is displayed even when there is no JAM. <table border="1"> <thead> <tr> <th>Key operation</th> <th>Display</th> </tr> </thead> <tbody> <tr> <td>JAM history select: Magnification ratio display key</td> <td>The history number (1 ~ 30) is displayed on the display. The JAM position LED corresponding to the history number is lighted.</td> </tr> </tbody> </table>	Key operation	Display	JAM history select: Magnification ratio display key	The history number (1 ~ 30) is displayed on the display. The JAM position LED corresponding to the history number is lighted.								
	Key operation	Display													
	JAM history select: Magnification ratio display key	The history number (1 ~ 30) is displayed on the display. The JAM position LED corresponding to the history number is lighted.													
	4	Total JAM counter display	Used to display the current total JAM counter value. *1												
	5	Total counter display	Used to display the current total counter value. *1												
	6	Developing counter display	Used to display the current developing unit counter value. *1												
	7	Developing preset counter value display <Japan only>	Used to display the current mini maintenance preset value (set with SIM 21-2). *1												
	8	SPF counter display <Only when an SPF/RSPF is installed>	Used to display the current SPF counter value. *1												
9	Paper feed counter display	Used to display the current paper feed counter value for each paper feed port. *1 <table border="1"> <thead> <tr> <th>Key operation</th> </tr> </thead> <tbody> <tr> <td>Paper feed port selection: Tray select key</td> </tr> </tbody> </table>	Key operation	Paper feed port selection: Tray select key											
Key operation															
Paper feed port selection: Tray select key															
12	Drum counter display	Used to display the current drum counter value. *1													
14	Copier ROM version display	Used to display the version number of the main ROM. <table border="1"> <thead> <tr> <th>Display</th> </tr> </thead> <tbody> <tr> <td>(Example) When the ROM version is 4.01: 004 → Blank → 001 → Blank → Repetition</td> </tr> </tbody> </table>	Display	(Example) When the ROM version is 4.01: 004 → Blank → 001 → Blank → Repetition											
Display															
(Example) When the ROM version is 4.01: 004 → Blank → 001 → Blank → Repetition															
15	Trouble memory display	Used to display the actually occurred trouble codes on the display on the operation panel. When the start key is pressed during the main code display, the sub code is displayed. Max. 20 recent trouble codes are stored. <table border="1"> <thead> <tr> <th>Key operation</th> <th>Display</th> </tr> </thead> <tbody> <tr> <td>Sub code display: Start key Trouble code history select: Magnification ratio display key</td> <td> Histories 1 ~ 10: The upper digit of display "A" ~ "J" lights up. Histories 11 ~ 20: The upper digit of display "A" ~ "J" blinks. ● Display without trouble code Main code: "– –" Sub code: "00" </td> </tr> </tbody> </table>	Key operation	Display	Sub code display: Start key Trouble code history select: Magnification ratio display key	Histories 1 ~ 10: The upper digit of display "A" ~ "J" lights up. Histories 11 ~ 20: The upper digit of display "A" ~ "J" blinks. ● Display without trouble code Main code: "– –" Sub code: "00"									
Key operation	Display														
Sub code display: Start key Trouble code history select: Magnification ratio display key	Histories 1 ~ 10: The upper digit of display "A" ~ "J" lights up. Histories 11 ~ 20: The upper digit of display "A" ~ "J" blinks. ● Display without trouble code Main code: "– –" Sub code: "00"														

*1: Each counter display method

To display 123456: 123 (0.75 sec) → Blank (0.35 sec) → 456 (0.75 sec) → Blank (1.0 sec) → repetition

*2: Display after clearing each counter

000 (0.75 sec) → Blank (0.35 sec) → 000 (0.75 sec) → Blank (1.0 sec) → Repetition

Main code	Sub code	Contents	Details of operation	Initial value	Set range
22	16	Duplex print counter display <Only AR-206/207>	Used to display the current duplex print counter value. *1		
	17	Copy counter display	Used to display the current copy counter value. *1		
	18	Printer counter display <Only when a printer function is installed>	Used to display the current printer counter value. *1		
	19	Electronic sort counter display <Only when an E-sort function is installed>	Used to display the current electronic sort counter value. *1		
	21	Scanner counter display	Used to display the current scanner counter value.		
24	1	JAM memory, JAM counter clear	Used to clear the JAM memory and the JAM counter. *2		
	2	Trouble memory clear	Used to clear the trouble memory. *2		
	4	SPF counter clear <Only when an SPF/RSPF is installed>	Used to clear the SPF counter. *2		
	5	Duplex counter clear <Only AR-206/207>	Used to clear the duplex counter. *2		
	6	Paper feed counter clear	Used to clear the paper feed counter. *2		
	7	Drum counter clear	Used to clear the drum counter. *2		
	8	Copy counter clear	Used to clear the copy counter. *2		
	9	Printer counter clear <Only when a printer function is installed>	Used to clear the printer counter. *2		
	10	Electronic sort counter clear <Only when an E-sort function is installed>	Used to clear the electronic sort counter. *2		
	13	Scanner counter clear	Used to clear the scanner counter. *2		
25	1	Main motor operation check	Execute the simulation with the developer cartridge removed, and the main motor will rotate for 30 sec. At that time, the cooling motor rotates at a low speed.		
	10	Polygon motor operation check	Used to drive the polygon motor for 30 sec.		

*2: Display after clearing each counter

000 (0.75 sec) → Blank (0.35 sec) → 000 (0.75 sec) → Blank (1.0 sec) → Repetition

Main code	Sub code	Contents	Details of operation	Initial value	Set range						
26	1	Option switch display	<p>Used to display the installed option on the operation panel. (The LED corresponding to the installed option is lighted.)</p> <table border="1"> <thead> <tr> <th>Key operation</th> <th>Display</th> </tr> </thead> <tbody> <tr> <td>Display select:</td> <td><Lighting with an option installed></td> </tr> <tr> <td>Magnification ratio display key</td> <td> <p>When "A" is displayed: Shifter: Paper empty LED Job separator: JAM LED SPF: SPF select LED RSPF: SPF JAM LED Duplex mode: Main cassette select LED Simplex mode: Multi manual paper feed select LED MCU JMPER1: Top of the magnification ratio display MCU JMPER2: 2nd of the magnification ratio display MCU JMPER3: 3rd of the magnification ratio display MCU JMPER7: 4th of the magnification ratio display MCU JMPER7: 5th of the magnification ratio display MCU JMPER7: 6th of the magnification ratio display MCU JMPER7: 7th of the magnification ratio display MCU JMPER8: Bottom of the magnification ratio display</p> <p>When "b" is displayed: Cassette (2nd step): No. 2 cassette select LED Cassette (3rd step): No. 3 cassette select LED Cassette (4th step): No. 4 cassette select LED Memory installed: Paper empty LED FAX: JAM LED Printer: Main body JAM LED ERDH: Main cassette select LED 16CPM: SPF JAM LED 20CPM: SPF select LED Document sensor: Auto paper select LED</p> </td> </tr> </tbody> </table>	Key operation	Display	Display select:	<Lighting with an option installed>	Magnification ratio display key	<p>When "A" is displayed: Shifter: Paper empty LED Job separator: JAM LED SPF: SPF select LED RSPF: SPF JAM LED Duplex mode: Main cassette select LED Simplex mode: Multi manual paper feed select LED MCU JMPER1: Top of the magnification ratio display MCU JMPER2: 2nd of the magnification ratio display MCU JMPER3: 3rd of the magnification ratio display MCU JMPER7: 4th of the magnification ratio display MCU JMPER7: 5th of the magnification ratio display MCU JMPER7: 6th of the magnification ratio display MCU JMPER7: 7th of the magnification ratio display MCU JMPER8: Bottom of the magnification ratio display</p> <p>When "b" is displayed: Cassette (2nd step): No. 2 cassette select LED Cassette (3rd step): No. 3 cassette select LED Cassette (4th step): No. 4 cassette select LED Memory installed: Paper empty LED FAX: JAM LED Printer: Main body JAM LED ERDH: Main cassette select LED 16CPM: SPF JAM LED 20CPM: SPF select LED Document sensor: Auto paper select LED</p>		
Key operation	Display										
Display select:	<Lighting with an option installed>										
Magnification ratio display key	<p>When "A" is displayed: Shifter: Paper empty LED Job separator: JAM LED SPF: SPF select LED RSPF: SPF JAM LED Duplex mode: Main cassette select LED Simplex mode: Multi manual paper feed select LED MCU JMPER1: Top of the magnification ratio display MCU JMPER2: 2nd of the magnification ratio display MCU JMPER3: 3rd of the magnification ratio display MCU JMPER7: 4th of the magnification ratio display MCU JMPER7: 5th of the magnification ratio display MCU JMPER7: 6th of the magnification ratio display MCU JMPER7: 7th of the magnification ratio display MCU JMPER8: Bottom of the magnification ratio display</p> <p>When "b" is displayed: Cassette (2nd step): No. 2 cassette select LED Cassette (3rd step): No. 3 cassette select LED Cassette (4th step): No. 4 cassette select LED Memory installed: Paper empty LED FAX: JAM LED Printer: Main body JAM LED ERDH: Main cassette select LED 16CPM: SPF JAM LED 20CPM: SPF select LED Document sensor: Auto paper select LED</p>										
	3	Auditor setting	<p>Used to display the current auditor setting with the numbers at right. After entering the set value, press the start key, and the set value is stored.</p> <table border="1"> <thead> <tr> <th>Key operation/Display</th> </tr> </thead> <tbody> <tr> <td>0: Built-in auditor</td> </tr> <tr> <td>1: Coin vendor</td> </tr> <tr> <td>2: Others</td> </tr> </tbody> </table>	Key operation/Display	0: Built-in auditor	1: Coin vendor	2: Others	0	0 ~ 2		
Key operation/Display											
0: Built-in auditor											
1: Coin vendor											
2: Others											
	5	Counter mode setting	<p>Used to set the print counter mode in A3 or 11" × 17". Used to display the currently set counter value with the numbers at right. After entering the set value, press the start key, and the set value is stored.</p> <table border="1"> <thead> <tr> <th>Key operation/Display</th> </tr> </thead> <tbody> <tr> <td>0: Total/Developer = 2 counts Maintenance = 2 counts</td> </tr> <tr> <td>1: Total/Developer = 1 count Maintenance = 2 counts</td> </tr> <tr> <td>2: Total/Developer = 2 counts Maintenance = 1 count</td> </tr> <tr> <td>3: Total/Developer = 1 count Maintenance = 1 count</td> </tr> </tbody> </table>	Key operation/Display	0: Total/Developer = 2 counts Maintenance = 2 counts	1: Total/Developer = 1 count Maintenance = 2 counts	2: Total/Developer = 2 counts Maintenance = 1 count	3: Total/Developer = 1 count Maintenance = 1 count	0	0 ~ 3	
Key operation/Display											
0: Total/Developer = 2 counts Maintenance = 2 counts											
1: Total/Developer = 1 count Maintenance = 2 counts											
2: Total/Developer = 2 counts Maintenance = 1 count											
3: Total/Developer = 1 count Maintenance = 1 count											

Main code	Sub code	Contents	Details of operation	Initial value	Set range																																				
26	6	Destination setting	<p>Used to display the current destination setting with the numbers at right. After entering the set value, press the start key, and the set value is stored.</p> <table border="1"> <thead> <tr> <th colspan="2">Key operation/Display</th> </tr> </thead> <tbody> <tr> <td>0: Japan</td> <td>8: EX AB series</td> </tr> <tr> <td>1: USA (Inch series)</td> <td>9: EX inch series (FC conformity)</td> </tr> <tr> <td>2: Canada (Inch series)</td> <td>10: EX AB series (FC conformity)</td> </tr> <tr> <td>3: Germany 1 (AB series)</td> <td>(Australia, Newzealand)</td> </tr> <tr> <td>4: UK (AB series)</td> <td>11: China (AB series)</td> </tr> <tr> <td>5: Not used</td> <td>12: Taiwan (AB series)</td> </tr> <tr> <td>6: France (AB series)</td> <td>13: Germany 2 (AB series)</td> </tr> <tr> <td>7: EX inch series</td> <td></td> </tr> </tbody> </table>	Key operation/Display		0: Japan	8: EX AB series	1: USA (Inch series)	9: EX inch series (FC conformity)	2: Canada (Inch series)	10: EX AB series (FC conformity)	3: Germany 1 (AB series)	(Australia, Newzealand)	4: UK (AB series)	11: China (AB series)	5: Not used	12: Taiwan (AB series)	6: France (AB series)	13: Germany 2 (AB series)	7: EX inch series		0	0 ~ 11																		
Key operation/Display																																									
0: Japan	8: EX AB series																																								
1: USA (Inch series)	9: EX inch series (FC conformity)																																								
2: Canada (Inch series)	10: EX AB series (FC conformity)																																								
3: Germany 1 (AB series)	(Australia, Newzealand)																																								
4: UK (AB series)	11: China (AB series)																																								
5: Not used	12: Taiwan (AB series)																																								
6: France (AB series)	13: Germany 2 (AB series)																																								
7: EX inch series																																									
	7	CRUM set value display	<p>The currently set value of CRUM is displayed with the following numbers:</p> <table border="1"> <thead> <tr> <th colspan="2">Key operation/Display</th> </tr> </thead> <tbody> <tr> <td>0: Not set</td> <td>3: BTA-C</td> </tr> <tr> <td>1: BTA-A</td> <td>99: Conv</td> </tr> <tr> <td>2: BTA-B</td> <td></td> </tr> </tbody> </table>	Key operation/Display		0: Not set	3: BTA-C	1: BTA-A	99: Conv	2: BTA-B																															
Key operation/Display																																									
0: Not set	3: BTA-C																																								
1: BTA-A	99: Conv																																								
2: BTA-B																																									
	10	Model name setting	<p>Used to set the model name of the machine used with the following numbers. After entering the set value, press the start key and the set value is stored.</p> <table border="1"> <thead> <tr> <th colspan="3">Key operation/Display</th> </tr> </thead> <tbody> <tr> <td>0: AL-1600</td> <td>11: AR-N200</td> <td>23: AR-162/S162</td> </tr> <tr> <td>1: AL-1610</td> <td>12: AR-N205</td> <td>24: AR-163/S163</td> </tr> <tr> <td>2: AL-1620</td> <td>13: AL-1621</td> <td>25: AR-201S</td> </tr> <tr> <td>3: AL-1640/AL-1641</td> <td>14: AL-1650</td> <td>26: AR-201/S201</td> </tr> <tr> <td>4: AR-160/AR-S160</td> <td>15: AL-1670</td> <td>27: AR-206/S206</td> </tr> <tr> <td>5: AR-161/AR-S161</td> <td>16: AR-F200</td> <td>28: AR-207</td> </tr> <tr> <td>6: AR-200S</td> <td>17: DM-2000</td> <td>29: ARF161</td> </tr> <tr> <td>7: AR-200/AR-S200</td> <td>18: DM-2005</td> <td>30: ARF201</td> </tr> <tr> <td>8: AR-205/AR-S205</td> <td>19: DM-2010</td> <td></td> </tr> <tr> <td>9: AR-F160</td> <td>20: DM-2015</td> <td></td> </tr> <tr> <td>10: AR-F205</td> <td></td> <td></td> </tr> </tbody> </table>	Key operation/Display			0: AL-1600	11: AR-N200	23: AR-162/S162	1: AL-1610	12: AR-N205	24: AR-163/S163	2: AL-1620	13: AL-1621	25: AR-201S	3: AL-1640/AL-1641	14: AL-1650	26: AR-201/S201	4: AR-160/AR-S160	15: AL-1670	27: AR-206/S206	5: AR-161/AR-S161	16: AR-F200	28: AR-207	6: AR-200S	17: DM-2000	29: ARF161	7: AR-200/AR-S200	18: DM-2005	30: ARF201	8: AR-205/AR-S205	19: DM-2010		9: AR-F160	20: DM-2015		10: AR-F205			0	0 ~ 30
Key operation/Display																																									
0: AL-1600	11: AR-N200	23: AR-162/S162																																							
1: AL-1610	12: AR-N205	24: AR-163/S163																																							
2: AL-1620	13: AL-1621	25: AR-201S																																							
3: AL-1640/AL-1641	14: AL-1650	26: AR-201/S201																																							
4: AR-160/AR-S160	15: AL-1670	27: AR-206/S206																																							
5: AR-161/AR-S161	16: AR-F200	28: AR-207																																							
6: AR-200S	17: DM-2000	29: ARF161																																							
7: AR-200/AR-S200	18: DM-2005	30: ARF201																																							
8: AR-205/AR-S205	19: DM-2010																																								
9: AR-F160	20: DM-2015																																								
10: AR-F205																																									
	22	Language setting	<p>Used to display the current setting of the language information with the number at right. After entering the set value, press the start key, and the set value is stored.</p> <table border="1"> <thead> <tr> <th colspan="2">Key operation/Display</th> </tr> </thead> <tbody> <tr> <td>0: Japanese</td> <td>4: Italian</td> </tr> <tr> <td>1: English</td> <td>5: Dutch</td> </tr> <tr> <td>2: French</td> <td>6: Swedish</td> </tr> <tr> <td>3: German</td> <td>7: Spanish</td> </tr> </tbody> </table>	Key operation/Display		0: Japanese	4: Italian	1: English	5: Dutch	2: French	6: Swedish	3: German	7: Spanish	0	0 ~ 7																										
Key operation/Display																																									
0: Japanese	4: Italian																																								
1: English	5: Dutch																																								
2: French	6: Swedish																																								
3: German	7: Spanish																																								
	30	CE mark conformity control setting	<p>Used to display the current setting of CE mark conformity control with the number at right. After entering the set value, press the start key, and the set value is stored.</p> <table border="1"> <thead> <tr> <th colspan="2">Key operation/Display</th> </tr> </thead> <tbody> <tr> <td>0: CE mark control OFF</td> <td></td> </tr> <tr> <td>1: CE mark control ON</td> <td></td> </tr> </tbody> </table>	Key operation/Display		0: CE mark control OFF		1: CE mark control ON		0	0 ~ 1																														
Key operation/Display																																									
0: CE mark control OFF																																									
1: CE mark control ON																																									
	32	Fan rotation duty change state setup	<p>The currently set fan motor rotation duty is displayed with the following numbers. After entering the set value, press the start key to store the set value.</p> <table border="1"> <thead> <tr> <th colspan="2">Key operation/Display</th> </tr> </thead> <tbody> <tr> <td>0: Operating 50%, standby 30%</td> <td></td> </tr> <tr> <td>1: Operating 80%, standby 50%</td> <td></td> </tr> </tbody> </table>	Key operation/Display		0: Operating 50%, standby 30%		1: Operating 80%, standby 50%		0	0.1																														
Key operation/Display																																									
0: Operating 50%, standby 30%																																									
1: Operating 80%, standby 50%																																									

Main code	Sub code	Contents	Details of operation	Initial value	Set range											
26	37	Cancel of stop at developer life over	<p>The currently set value is displayed. Enter a set value and press the START key, then the set value is registered.</p> <table border="1"> <tr> <td>Key operation/Display</td> </tr> <tr> <td>0: Stops the machine at developer life over.</td> </tr> <tr> <td>1: Does not stop the machine at developer life over.</td> </tr> </table>	Key operation/Display	0: Stops the machine at developer life over.	1: Does not stop the machine at developer life over.	1	0 ~ 1								
Key operation/Display																
0: Stops the machine at developer life over.																
1: Does not stop the machine at developer life over.																
	38	Cancel of stop at drum life over <Not Used>	<p>The currently set value is displayed. After entering the set value, press the start key to store the set value.</p> <table border="1"> <tr> <td>Key operation/Display</td> </tr> <tr> <td>0: The machine stops at drum life over.</td> </tr> <tr> <td>1: The machine does not stop at drum life over.</td> </tr> </table>	Key operation/Display	0: The machine stops at drum life over.	1: The machine does not stop at drum life over.	0	0 ~ 1								
Key operation/Display																
0: The machine stops at drum life over.																
1: The machine does not stop at drum life over.																
	42	Transfer timing adjustment	<p>After completion of warm up, shading is performed and the currently set transfer timing adjustment value is displayed.</p> <table border="1"> <tr> <td>Key operation</td> </tr> <tr> <td>Transfer timing adjustment value: Copy quantity keys</td> </tr> <tr> <td>"1": 240 ms</td> </tr> <tr> <td>"3": 260 ms</td> </tr> <tr> <td>"5": 280 ms</td> </tr> <tr> <td>"7": 300 ms</td> </tr> <tr> <td>"9": 320 ms</td> </tr> </table>	Key operation	Transfer timing adjustment value: Copy quantity keys	"1": 240 ms	"3": 260 ms	"5": 280 ms	"7": 300 ms	"9": 320 ms	5	1, 3, 5, 7, 9				
Key operation																
Transfer timing adjustment value: Copy quantity keys																
"1": 240 ms																
"3": 260 ms																
"5": 280 ms																
"7": 300 ms																
"9": 320 ms																
	50	Black-white reversion function setup	<p>The current setup of black-white reversion is displayed with the following numbers. After entering the set value, press the start key to store the set value.</p> <table border="1"> <tr> <td>Key operation/Display</td> </tr> <tr> <td>0: Black-white reversion function enabled</td> </tr> <tr> <td>1: Black-white reversion function disabled</td> </tr> </table>	Key operation/Display	0: Black-white reversion function enabled	1: Black-white reversion function disabled	0	0.1								
Key operation/Display																
0: Black-white reversion function enabled																
1: Black-white reversion function disabled																
	51	Sort/Group copy temporary stop function setup <Only when an E-sort function is installed>	<p>Used to set whether temporary stop for every 250-sheet print (150-sheet print when the job separator is installed) is made or not during copying with the sort/group function. The current setup is displayed with the following numbers. After entering the set value, press the start key to store the set value.</p> <table border="1"> <tr> <td>Key operation/Display</td> </tr> <tr> <td>0: Does not stop.</td> </tr> <tr> <td>1: Stops.</td> </tr> </table>	Key operation/Display	0: Does not stop.	1: Stops.	1	0.1								
Key operation/Display																
0: Does not stop.																
1: Stops.																
30	1	Machine sensor operation check	<p>Used to check the sensors in the machine transport system with LED on the operation panel.</p> <table border="1"> <tr> <td>Display</td> </tr> <tr> <td><Lighting at sensor ON></td> </tr> <tr> <td>Paper entry sensor: Machine position JAM LED</td> </tr> <tr> <td>Duplex sensor: SPF JAM LED <Only AR-206/207></td> </tr> <tr> <td>Paper exit sensor: JAM LED</td> </tr> <tr> <td>No. 2 cassette transport sensor: No. 2 cassette position LED</td> </tr> <tr> <td>No. 3 cassette transport sensor: No. 3 cassette position LED</td> </tr> <tr> <td><Only when an option is installed></td> </tr> <tr> <td>No. 4 cassette transport sensor: No. 4 cassette position LED</td> </tr> <tr> <td><Only when an option is installed></td> </tr> <tr> <td>Drum initial SW: DRUM LED</td> </tr> </table>	Display	<Lighting at sensor ON>	Paper entry sensor: Machine position JAM LED	Duplex sensor: SPF JAM LED <Only AR-206/207>	Paper exit sensor: JAM LED	No. 2 cassette transport sensor: No. 2 cassette position LED	No. 3 cassette transport sensor: No. 3 cassette position LED	<Only when an option is installed>	No. 4 cassette transport sensor: No. 4 cassette position LED	<Only when an option is installed>	Drum initial SW: DRUM LED		
Display																
<Lighting at sensor ON>																
Paper entry sensor: Machine position JAM LED																
Duplex sensor: SPF JAM LED <Only AR-206/207>																
Paper exit sensor: JAM LED																
No. 2 cassette transport sensor: No. 2 cassette position LED																
No. 3 cassette transport sensor: No. 3 cassette position LED																
<Only when an option is installed>																
No. 4 cassette transport sensor: No. 4 cassette position LED																
<Only when an option is installed>																
Drum initial SW: DRUM LED																
41	2	OC document sensor adjustment <Other than AR-162>	<p>Used to read the document sensor input value with paper and perform the sensor detection level adjustment. For the adjustment procedure of the document sensor input value, refer to the previous descriptions.</p>													

Main code	Sub code	Contents	Details of operation	Initial value	Set range				
41	3	Document sensor light reception level display <Other than AR-162>	Used to display the light reception level and the detection level of the document sensor. (The sensor level adjusted with SIM 41-2 is displayed.) <table border="1"> <thead> <tr> <th>Key operation</th> <th>Display</th> </tr> </thead> <tbody> <tr> <td>Light reception/Detection level select: Magnification ratio display key Sensor select: Auto magnification ratio select key</td> <td>Display at the 3rd digit "A": Light reception level display "b": Document detection level display Sensor A: A3 (11 × 17) document size LED Sensor B: A4 (8 1/2 × 14) document size LED Sensor C: A4R (8 1/2 × 11) document size LED Sensor D: B4 (8 1/2 × 5 1/2) document size LED</td> </tr> </tbody> </table>	Key operation	Display	Light reception/Detection level select: Magnification ratio display key Sensor select: Auto magnification ratio select key	Display at the 3rd digit "A": Light reception level display "b": Document detection level display Sensor A: A3 (11 × 17) document size LED Sensor B: A4 (8 1/2 × 14) document size LED Sensor C: A4R (8 1/2 × 11) document size LED Sensor D: B4 (8 1/2 × 5 1/2) document size LED		
Key operation	Display								
Light reception/Detection level select: Magnification ratio display key Sensor select: Auto magnification ratio select key	Display at the 3rd digit "A": Light reception level display "b": Document detection level display Sensor A: A3 (11 × 17) document size LED Sensor B: A4 (8 1/2 × 14) document size LED Sensor C: A4R (8 1/2 × 11) document size LED Sensor D: B4 (8 1/2 × 5 1/2) document size LED								
42	1	Developing counter clear	Used to clear the Developing counter. *2						
43	1	Fusing temperature setting	Used to display the current setting of the fusing temperature at right. After selecting the fusing temperature with the magnification ratio display key, press the start key, and the set value is stored. The set range is 155 ~ 190°C. Use the magnification ratio key to adjust the value by -5°C. <table border="1"> <thead> <tr> <th>Key operation</th> </tr> </thead> <tbody> <tr> <td>Fusing temperature select: Magnification ratio display key</td> </tr> </tbody> </table>	Key operation	Fusing temperature select: Magnification ratio display key	170	155 ~ 190		
Key operation									
Fusing temperature select: Magnification ratio display key									
46	1	Copy density level adjustment	After completion of warmup, shading is performed and the currently set copy density level is displayed. For the adjustment procedure, refer to the previous descriptions. <table border="1"> <thead> <tr> <th>Key operation</th> <th>Display</th> </tr> </thead> <tbody> <tr> <td>Mode select: Exposure mode select key Copy density level: Copy quantity keys</td> <td><LED lighting at each mode selection> Auto mode: AUTO LED Manual mode: MANUAL LED Photo mode: PHOTO LED Toner save mode: MANUAL + PHOTO LED AETS mode: AUTO + PHOTO LED</td> </tr> </tbody> </table>	Key operation	Display	Mode select: Exposure mode select key Copy density level: Copy quantity keys	<LED lighting at each mode selection> Auto mode: AUTO LED Manual mode: MANUAL LED Photo mode: PHOTO LED Toner save mode: MANUAL + PHOTO LED AETS mode: AUTO + PHOTO LED	48	1 ~ 99
Key operation	Display								
Mode select: Exposure mode select key Copy density level: Copy quantity keys	<LED lighting at each mode selection> Auto mode: AUTO LED Manual mode: MANUAL LED Photo mode: PHOTO LED Toner save mode: MANUAL + PHOTO LED AETS mode: AUTO + PHOTO LED								
	19	AE mode picture quality change	The currently set AE picture quality mode (gamma table) is displayed with the following set values. Enter a set value and press the START key, then the set value will be inputted. <table border="1"> <thead> <tr> <th>Key operation/Display</th> </tr> </thead> <tbody> <tr> <td>1: Picture quality priority mode</td> </tr> <tr> <td>2: Toner consumption priority mode</td> </tr> </tbody> </table>	Key operation/Display	1: Picture quality priority mode	2: Toner consumption priority mode	1	1 ~ 2	
Key operation/Display									
1: Picture quality priority mode									
2: Toner consumption priority mode									
48	1	Main scanning (front/rear) direction magnification ratio adjustment (Copy/FAX/OC-SPF common)	After completion of warmup, shading is performed and the currently set main scanning (front/rear) direction magnification ratio adjustment and the OC mode document center off adjustment are performed. For the adjustment procedure, refer to the previous descriptions. <table border="1"> <thead> <tr> <th>Key operation</th> <th>Display</th> </tr> </thead> <tbody> <tr> <td>Adjustment mode select: Magnification ratio display key Manual main scanning direction magnification ratio adjustment Set value: Copy quantity keys</td> <td>Auto magnification ratio adjustment: AUTO LED Manual magnification ratio adjustment: MANUAL LED OC mode document center off adjustment: PHOTO LED</td> </tr> </tbody> </table>	Key operation	Display	Adjustment mode select: Magnification ratio display key Manual main scanning direction magnification ratio adjustment Set value: Copy quantity keys	Auto magnification ratio adjustment: AUTO LED Manual magnification ratio adjustment: MANUAL LED OC mode document center off adjustment: PHOTO LED	58	1 ~ 99
Key operation	Display								
Adjustment mode select: Magnification ratio display key Manual main scanning direction magnification ratio adjustment Set value: Copy quantity keys	Auto magnification ratio adjustment: AUTO LED Manual magnification ratio adjustment: MANUAL LED OC mode document center off adjustment: PHOTO LED								
	2	OC mode sub scanning direction magnification ratio adjustment in copying	After completion of warmup, shading is performed and the currently set OC mode sub scanning direction magnification ratio adjustment in copying is performed. For the adjustment procedure, refer to the previous descriptions. <table border="1"> <thead> <tr> <th>Key operation</th> </tr> </thead> <tbody> <tr> <td>OC mode sub scanning direction magnification ratio in copying: Copy quantity keys</td> </tr> </tbody> </table>	Key operation	OC mode sub scanning direction magnification ratio in copying: Copy quantity keys	50	1 ~ 99		
Key operation									
OC mode sub scanning direction magnification ratio in copying: Copy quantity keys									

*2: Display after clearing each counter
000 (0.75 sec) → Blank (0.35 sec) → 000 (0.75 sec) → Blank (1.0 sec) → Repetition

Main code	Sub code	Contents	Details of operation	Initial value	Set range						
48	5	SPF mode sub scanning direction magnification ratio adjustment in copying <Only when an SPF/RSPF is installed>	<p>After completion of warmup, shading is performed and the currently set SPF mode sub scanning direction magnification ratio adjustment in copying is performed. For the adjustment procedure, refer to the previous descriptions.</p> <table border="1"> <thead> <tr> <th>Key operation</th> <th>Display</th> </tr> </thead> <tbody> <tr> <td>Adjustment mode select: Exposure mode select key</td> <td>Auto: SPF mode sub scanning direction magnification ratio in copying Manual: RSPF mode sub scanning direction magnification ratio in copying</td> </tr> <tr> <td>Set value: Copy quantity keys</td> <td></td> </tr> </tbody> </table>	Key operation	Display	Adjustment mode select: Exposure mode select key	Auto: SPF mode sub scanning direction magnification ratio in copying Manual: RSPF mode sub scanning direction magnification ratio in copying	Set value: Copy quantity keys		33 45	1 ~ 99
Key operation	Display										
Adjustment mode select: Exposure mode select key	Auto: SPF mode sub scanning direction magnification ratio in copying Manual: RSPF mode sub scanning direction magnification ratio in copying										
Set value: Copy quantity keys											
50	1	Copy image position adjustment	<p>After completion of warmup, shading is performed and the currently set value is displayed. For the adjustment procedure, refer to the previous descriptions.</p> <table border="1"> <thead> <tr> <th>Key operation</th> <th>Display</th> </tr> </thead> <tbody> <tr> <td>Adjustment mode select: Exposure mode select key</td> <td>Auto: Copy lead edge adjustment Manual: SPF lead edge adjustment <Not used> Photo: Main cassette lead edge void adjustment</td> </tr> <tr> <td>Set value: Copy quantity keys</td> <td>Auto + Manual: Left edge void adjustment Auto + Photo: Rear edge void adjustment Auto + Manual + Photo: Option cassette lead edge void adjustment Manual + Photo: Multi bypass tray lead edge void adjustment None: Duplex lead edge void adjustment <Only AR-206/207> Exposure 1: Print start position adjustment Exposure 3: Duplex lead edge adjustment <Only AR-206/207> Exposure 5: Duplex rear edge void adjustment <Only AR-206/207></td> </tr> </tbody> </table>	Key operation	Display	Adjustment mode select: Exposure mode select key	Auto: Copy lead edge adjustment Manual: SPF lead edge adjustment <Not used> Photo: Main cassette lead edge void adjustment	Set value: Copy quantity keys	Auto + Manual: Left edge void adjustment Auto + Photo: Rear edge void adjustment Auto + Manual + Photo: Option cassette lead edge void adjustment Manual + Photo: Multi bypass tray lead edge void adjustment None: Duplex lead edge void adjustment <Only AR-206/207> Exposure 1: Print start position adjustment Exposure 3: Duplex lead edge adjustment <Only AR-206/207> Exposure 5: Duplex rear edge void adjustment <Only AR-206/207>	55 77 18 48 40 18 18 20 55 60 60	1 ~ 99
Key operation	Display										
Adjustment mode select: Exposure mode select key	Auto: Copy lead edge adjustment Manual: SPF lead edge adjustment <Not used> Photo: Main cassette lead edge void adjustment										
Set value: Copy quantity keys	Auto + Manual: Left edge void adjustment Auto + Photo: Rear edge void adjustment Auto + Manual + Photo: Option cassette lead edge void adjustment Manual + Photo: Multi bypass tray lead edge void adjustment None: Duplex lead edge void adjustment <Only AR-206/207> Exposure 1: Print start position adjustment Exposure 3: Duplex lead edge adjustment <Only AR-206/207> Exposure 5: Duplex rear edge void adjustment <Only AR-206/207>										
	10	Paper off center adjustment	<p>After completion of warmup, shading is performed and the currently set off center adjustment of each paper feed port is displayed. For the adjustment procedure, refer to the previous descriptions.</p> <table border="1"> <thead> <tr> <th>Key operation</th> <th>Display</th> </tr> </thead> <tbody> <tr> <td>Paper feed port tray select: Tray select key</td> <td>Main cassette: Main cassette select LED</td> </tr> <tr> <td>Off center adjustment value: numeric keys</td> <td>Manual paper feed: Manual feed select LED No. 2 cassette: No. 2 cassette select LED No. 3 cassette: No. 3 cassette select LED <Only when an option is installed> No. 4 cassette: No. 4 cassette select LED <Only when an option is installed> Duplex: None <Only AR-206/207></td> </tr> </tbody> </table>	Key operation	Display	Paper feed port tray select: Tray select key	Main cassette: Main cassette select LED	Off center adjustment value: numeric keys	Manual paper feed: Manual feed select LED No. 2 cassette: No. 2 cassette select LED No. 3 cassette: No. 3 cassette select LED <Only when an option is installed> No. 4 cassette: No. 4 cassette select LED <Only when an option is installed> Duplex: None <Only AR-206/207>	50	1 ~ 99
Key operation	Display										
Paper feed port tray select: Tray select key	Main cassette: Main cassette select LED										
Off center adjustment value: numeric keys	Manual paper feed: Manual feed select LED No. 2 cassette: No. 2 cassette select LED No. 3 cassette: No. 3 cassette select LED <Only when an option is installed> No. 4 cassette: No. 4 cassette select LED <Only when an option is installed> Duplex: None <Only AR-206/207>										
	13	OC mode document off center adjustment	<p>After completion of warmup, shading is performed and the currently set off center adjustment value for the document in OC reading is displayed. For the adjustment procedure, refer to the previous descriptions.</p> <table border="1"> <thead> <tr> <th>Key operation</th> </tr> </thead> <tbody> <tr> <td>Off center adjustment value: Copy quantity keys</td> </tr> </tbody> </table>	Key operation	Off center adjustment value: Copy quantity keys	50	1 ~ 99				
Key operation											
Off center adjustment value: Copy quantity keys											
	16	SPF mode document off center adjustment <Only when an SPF/RSPF is installed>	<p>After completion of warmup, shading is performed and the currently set off center adjustment value for the document in SPF reading is displayed. For the adjustment procedure, refer to the previous descriptions.</p> <table border="1"> <thead> <tr> <th>Key operation</th> </tr> </thead> <tbody> <tr> <td>Off center adjustment value: Copy quantity keys</td> </tr> </tbody> </table>	Key operation	Off center adjustment value: Copy quantity keys	61	1 ~ 99				
Key operation											
Off center adjustment value: Copy quantity keys											

Main code	Sub code	Contents	Details of operation	Initial value	Set range						
50	18	Duplex memory reverse position adjustment <Only when an duplex function is installed>	After completion of warmup, shading is performed and currently set value is displayed <table border="1"> <tr> <th colspan="2">Key operation</th> </tr> <tr> <td colspan="2">Memory reverse position adjustment value: Copy quantity keys</td> </tr> </table>	Key operation		Memory reverse position adjustment value: Copy quantity keys		58	1 ~ 99		
Key operation											
Memory reverse position adjustment value: Copy quantity keys											
50	19	Duplex rear edge void adjustment <Only when an duplex function is installed>	After completion of warmup, shading is performed and currently set value is displayed. <table border="1"> <tr> <th>Key operation</th> <th>Display</th> </tr> <tr> <td>Adjustment mode select: Exposure mode select key</td> <td>Auto: SPF/R-SPF rear edge void</td> </tr> <tr> <td>Set value: Copy quantity keys</td> <td>Manual: R-SPF off center Photo: R-SPF lead edge void</td> </tr> </table>	Key operation	Display	Adjustment mode select: Exposure mode select key	Auto: SPF/R-SPF rear edge void	Set value: Copy quantity keys	Manual: R-SPF off center Photo: R-SPF lead edge void	37 52 70	1 ~ 99
Key operation	Display										
Adjustment mode select: Exposure mode select key	Auto: SPF/R-SPF rear edge void										
Set value: Copy quantity keys	Manual: R-SPF off center Photo: R-SPF lead edge void										
51	2	Resist amount adjustment	After completion of warmup, shading is performed and the currently set resist amount adjustment value is displayed. <table border="1"> <tr> <th>Key operation</th> <th>Display</th> </tr> <tr> <td>Resist amount adjustment: Copy quantity keys</td> <td>Auto: Main cassette Manual: 2nd tray</td> </tr> <tr> <td>Adjustment mode select: Exposure mode select key</td> <td>Photo: Manual feed tray Auto + Manual: Duplex <Only AR-206/207> Auto + Photo: RSPF <Only when an option is installed></td> </tr> </table>	Key operation	Display	Resist amount adjustment: Copy quantity keys	Auto: Main cassette Manual: 2nd tray	Adjustment mode select: Exposure mode select key	Photo: Manual feed tray Auto + Manual: Duplex <Only AR-206/207> Auto + Photo: RSPF <Only when an option is installed>	50 1 50 50 48	1 ~ 99 (6 ~ 94 for the duplex only)
Key operation	Display										
Resist amount adjustment: Copy quantity keys	Auto: Main cassette Manual: 2nd tray										
Adjustment mode select: Exposure mode select key	Photo: Manual feed tray Auto + Manual: Duplex <Only AR-206/207> Auto + Photo: RSPF <Only when an option is installed>										
63	1	Shading data check	The copy lamp is shifted to the shading position and it is lighted with the reference voltage at AD conversion fixed ($V_{ref-} = 0.5V$, $V_{ref+} = 4.5V$). The level of one pixel at the center at that time is displayed. <table border="1"> <tr> <th>Display</th> </tr> <tr> <td>Display section: Shading data</td> </tr> </table>	Display	Display section: Shading data						
Display											
Display section: Shading data											
64	1	Self print mode	Disregards the optical system and performs self printing in 1 by 2mode.								
67	14	Printer Flash ROM Data Download <Only when printer function is installed>	The machine enters the version up mode of the printer control PWB flash ROM. For details, refer to the later.								

[8] USER PROGRAMS

The user programs allow the parameters of certain functions to be set, changed, or canceled as desired.

1. List of user programs



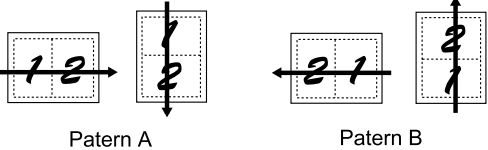
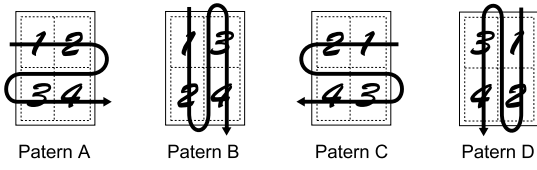

This copier has the following user programs.

Program name	Program No	Description	Default	Parameters
Auto clear time	1	Sets the auto clear time. The copier returns to the initial settings when the auto clear time elapses after the last copy is made.	60sec	0(OFF)
				1(30sec)
				2(60sec)
				3(90sec)
				4(120sec)
Preheat mode	2	Sets the time that elapses before the copier enters the preheat mode after any operation is made.	90sec	0(OFF)
				1(30sec)
				2(60sec)
				3(90sec)
				4(120sec)
Auto power shut-off timer	3	Sets the time that elapses before the copier enters the auto power shut-off mode after any operation is made.	30min	1(30min)
				2(60min)
				3(90min)
				4(120min)
				5(240min)
Stream feeding mode*	4	Enables or disables the stream feeding mode when an optional SPF or RSPF is installed.	OFF	0(OFF)
				1(ON)
Auto power shut-off setting	5	Enables or disables the auto power shut-off mode.	ON	0(OFF)
				1(ON)
Border line for 2 in 1 or 4 in 1*	6	Enables or disables the border line which is printed in 2 in 1 or 4 in 1 copying when an electronic sorting kit and an SPF or RSPF are installed.	OFF	0(OFF)
				1(ON)
Rotation copy*	7	Enables or disables rotation of original images.	ON	0(OFF)
				1(ON)
Auto paper select mode	8	Enables or disables the auto paper selection.	ON	0(OFF)
				1(ON)
Auto tray switching	9	Enables or disables the automatic tray switching which occurs when paper in a tray runs out. (This switching cannot switch to the bypass tray.)	ON	0(OFF)
				1(ON)
Auditing mode	10	Enables or disables the auditing mode, which controls access to copier.	OFF	0 (OFF)
				1 (ON)
Account number entry	11	Registers accounts for auditing mode.	–	–
Account number change	12	Changes account numbers for auditing mode.	–	–
Account number deletion	13	Deletes accounts for auditing mode.	–	–
Number of copies per account	14	Displays the total number of copies made against account numbers.	–	–
Resetting account	15	Resets all audit accounts or resets any desired individual account.	–	–
Erase width adjustment*	16	Sets the amount of the edge erase and center erase areas.	10mm[1/2"]	0(0mm[0"])
				1(5mm[1/4"])
				2(10mm[1/2"])
				3(15mm[3/4"])
				4(20mm[1"])

Program name	Program No	Description	Default	Parameters
Layout in 2 in 1 copy*	17	Selects a pattern for 2 in 1 copying.  Patern A Patern B	Pattern 1	1(Pattern 1)
				2(Pattern 2)
Layout in 4 in 1 copy*	18	Selects a pattern for 4 in 1 copying.  Patern A Patern B Patern C Patern D	Pattern 1	1(Pattern 1)
				2(Pattern 2)
				3(Pattern 3)
				4(Pattern 4)
Offset of paper output tray	19	Enables or disables the offset function of the paper output tray. The offset function can be specified respectively for the upper and lower areas separated by an optional job separator tray kit.	Upper ON, Lower ON	0(Upper OFF, Lower OFF)
				1(Upper ON, Lower On)
				2(Upper ON, Lower OFF)
				3(Upper OFF, Lower On)
Image rotation in duplex copying	20	Enables or disables image rotation (180°) of the front side in one-sided to two-sided copying or two-sided to one-sided copying.	OFF	0(OFF)
				1(ON)
Location of the margin*	22	Selects the location of the expanded margin.	Left	1(Left)
				2(Top)

* These programs do not affect the copier functions unless certain optional equipment is installed.

2. Setting the user programs

- Press and hold the light key for more than 5 seconds until all the alarm indicators (, , , , and ) blink and "-" appears in the copy quantity display.
- Enter a program number using the numeric keys.
 - The selected program number will blink in the copy quantity display.
 - If a mistake is made in steps 2) to 4), press the CLEAR key. The copier will return to step 2).

For example, to change the setting of the auto power shut-off timer, press key 3.

- Press the START key.
 - For programs 1 to 9 and 16 to 19, the entered program number will be steadily lit on the left side of the copy quantity display and the currently selected parameter number for the program will blink on the right side.
 - For programs 10 to 15 (programs for auditing accounts), the display varies with the program number.
- Select the desired parameter using the numeric keys.
 - The entered parameter number will blink on the right side of the copy quantity display.
 - The parameters are shown in the table below.

For example, to change the setting of the auto power shut-off timer to 60 min., press key 2.





** In European countries, the default setting of the preheat mode is 1 (30 sec.). For other programs, factory-default settings in these countries are same to those shown above with an asterisk (*).

Note: If you select "0" (OFF) in a program, the corresponding function will be disabled.

- Press the START key.
 - The right-hand number in the copy quantity display will be steadily lit and the entered value will be stored.
- To continue with other user programs, press the PRESS key and then repeat steps 2 to 5. To exit the user program mode, press the light key.
 - All the alarm indicators will go out.

3. Toner cartridge life

To find out the approximate quantity of toner remaining, follow the procedure below.

- Press and hold the light key for more than 5 seconds until all the alarm indicators (, , , , and ) blink and "-" appears in the copy quantity display.

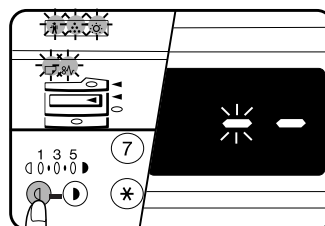

- Press and hold the copy ratio display key for more than 5 seconds.
 - The approximate quantity of toner remaining will be indicated as a percent in the copy quantity display. ("100", "75", "50", "25", "10" or "LO" is displayed. When "LO" is displayed, the toner is down to less than 10%.)

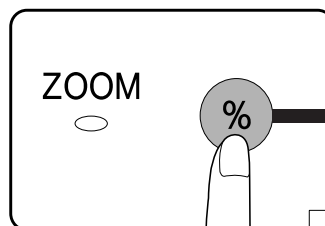

- Press the light key.
 - All the alarm indicators will go out.

[9] TROUBLE CODE LIST

1. Trouble code list

Trouble code	Trouble content	
E1	00	E-Sort board communication trouble
	10	E-Sort board trouble
	11	E-Sort ASIC error
	12	E-Sort CODEC error
	13	E-Sort flash ROM error
	14	E-Sort RAM error
	15	E-Sort page memory error
	16	E-Sort SIMM error
	17	Rotation RAM error
	80	E-Sort board communication trouble (Protocol)
	81	E-Sort board communication trouble (Parity)
	82	E-Sort board communication trouble (Overrun)
	84	E-Sort board communication trouble (Framing)
	88	E-Sort board communication trouble (Time-out)
E7	03	LSU trouble
	04	CCD white level trouble
	05	CCD black level trouble
F1	06	Shifter motor trouble
F2	04	CRUM data read trouble
F5	02	Copy lamp error
F6	00	FAX board communication trouble
	10	FAX board trouble
	80	FAX board communication trouble (Protocol)
	81	FAX board communication trouble (Parity)
	82	FAX board communication trouble (Overrun)
	84	FAX board communication trouble (Framing)
F9	00	Printer PWB communication trouble
	10	Printer PWB trouble
	80	Printer PWB communication trouble (Protocol)
	81	Printer PWB communication trouble (Parity)
	82	Printer PWB communication trouble (Overrun)
	84	Printer PWB communication trouble (Framing)
H2	00	Thermistor open detection
	00	Heat roller abnormally high temperature
	00	Heat roller abnormally low temperature
	00	Mirror base feed trouble
	00	Mirror base return trouble
	L4	01
10		Job separator motor abnormality
L6	10	Polygon motor lock
L8	01	Zero cross pulse (FW) trouble
U2	04	EEPROM serial communication error
	11	Counter check sum error
	12	Adjustment value check sum error (EEPROM)
	40	CRUM communication error
U3	29	Mirror base home position error

U9	00	Operation control PWB communication trouble
	80	Operation control PWB communication trouble (Protocol)
	81	Operation control PWB communication trouble (Parity)
	82	Operation control PWB communication trouble (Overrun)
	84	Operation control PWB communication trouble (Framing)
	88	Operation control PWB communication trouble (Time-out)
U95		Operation control PWB connection error
U99		Operation control PWB connection error

2. Details of trouble codes

Main code	Sub code		Detail of trouble
E1	00	Content	Communication trouble between MCU and E-Sort.
		Detail	Communication setup error, framing, parity, protocol error
		Cause	E-Sort PWB connector disconnection E-Sort PWB MCU PWB harness failure E-Sort Motherboard connector pin breakage. E-Sort PWB ROM defect, data failure
	10	Check and remedy	Check the connectors and harness of the E-Sort PWB and the MCU PWB. Check grounding of the machine. Check the ROM of the E-Sort PWB.
		Content	E-Sort PWB trouble
		Detail	Communication trouble between MCU and E-Sort
	11	Cause	E-Sort PWB connector disconnection E-Sort PWB MCU PWB harness failure E-Sort Motherboard connector pin breakage. E-Sort PWB ROM defect, data failure
		Check and remedy	Check the connectors and harness of the E-Sort PWB and the MCU PWB. Check grounding of the machine. Check the ROM of the E-Sort PWB.
		Content	E-Sort PWB ASIC error
11	Detail	E-Sort PWB ASIC abnormality	
	Cause	An ASIC abnormality is detected in the E-Sort PWB. Control circuit hung up due to noises ASIC peripheral circuit error	

Main code	Sub code		Detail of trouble
E1	11	Check and remedy	Replace the E-Sort PWB. Check grounding of the machine.
		12	Content
		Detail	E-Sort PWB CODEC error
		Cause	A CODEC error is detected in the E-Sort PWB. Control circuit hung up due to noises CODEC peripheral circuit error
		Check and remedy	Replace the E-Sort PWB. Check grounding of the machine.
	13	Content	E-Sort PWB Flash ROM error
		Detail	E-Sort PWB Flash ROM abnormality
		Cause	A Flash ROM abnormality is detected in the E-Sort PWB. Control circuit hung up due to noises Flash ROM peripheral circuit error
		Check and remedy	Replace the E-Sort PWB. Rewrite the flash ROM data. Check grounding of the machine.
	14	Content	E-Sort PWB Work RAM error
		Detail	E-Sort PWB Work RAM abnormality
		Cause	A Work RAM abnormality is detected in the E-Sort PWB. Control circuit hung up due to noises RAM peripheral circuit error
		Check and remedy	Replace the E-Sort PWB. Check grounding of the machine.
	15	Content	E-Sort PWB Page Memory error
		Detail	E-Sort PWB Page Memory abnormality
		Cause	A Page Memory abnormality is detected in the E-Sort PWB. Control circuit hung up due to noises Page Memory peripheral circuit error
		Check and remedy	Replace the E-Sort PWB. Check grounding of the machine.
	16	Content	E-Sort PWB SIMM error
		Detail	E-Sort PWB SIMM abnormality
		Cause	A SIMM abnormality is detected in the E-Sort PWB. Control circuit hung up due to noises SIMM peripheral circuit error
		Check and remedy	Replace the E-Sort PWB. Replace the SIMM. Check grounding of the machine.
17	Content	E-Sort PWB image rotating RAM error	
	Detail	E-Sort PWB image rotating RAM abnormality	

Main code	Sub code		Detail of trouble
E1	17	Cause	An image rotating RAM abnormality is detected in the E-Sort PWB. Control circuit hung up due to noises Image rotating RAM peripheral circuit error
		Check and remedy	Replace the E-Sort PWB. Check grounding of the machine.
	80	Content	E-Sort PWB communication trouble (protocol)
		Detail	Communication trouble between MCU and printer PWB (Protocol error)
		Cause	E-Sort PWB connector disconnection E-Sort PWB MCU PWB harness failure E-Sort Motherboard connector pin breakage. E-Sort PWB ROM defect, data failure
		Check and remedy	Check the connectors and harness of the E-Sort PWB and the MCU PWB. Check grounding of the machine. Check the ROM of the E-Sort PWB.
	81	Content	E-Sort PWB communication trouble (Parity)
		Detail	Communication trouble between MCU and printer E-Sort (Parity error)
		Cause	E-Sort PWB connector disconnection E-Sort PWB MCU PWB harness failure E-Sort Motherboard connector pin breakage. E-Sort PWB ROM defect, data failure
		Check and remedy	Check the connectors and harness of the E-Sort PWB and the MCU PWB. Check grounding of the machine. Check the ROM of the E-Sort PWB.
	82	Content	E-Sort PWB communication trouble (Overrun)
		Detail	Communication trouble between MCU and E-Sort PWB (Overrun error)
		Cause	E-Sort PWB connector disconnection E-Sort PWB MCU PWB harness failure E-Sort Motherboard connector pin breakage. E-Sort PWB ROM defect, data failure

Main code	Sub code		Detail of trouble
E1	82	Check and remedy	Check the connectors and harness of the E-Sort PWB and the MCU PWB. Check grounding of the machine. Check the ROM of the E-Sort PWB.
		Content	E-Sort PWB communication trouble (Framing)
			Detail
		Cause	E-Sort PWB connector disconnection E-Sort PWB MCU PWB harness failure E-Sort Motherboard connector pin breakage. E-Sort PWB ROM defect, data failure
	Check and remedy	Check the connectors and harness of the E-Sort PWB and the MCU PWB. Check grounding of the machine. Check the ROM of the E-Sort PWB.	
	88	Content	E-Sort PWB communication trouble (Time-out)
			Detail
		Cause	E-Sort PWB connector disconnection E-Sort PWB and MCU PWB harness failure E-Sort Motherboard connector pin breakage. E-Sort PWB ROM defect, data failure
		Check and remedy	Check the connectors and harness of the E-Sort PWB and the MCU PWB. Check grounding of the machine. Check the ROM of the E-Sort PWB.
	E7	03	Content
Detail			After the polygon motor becomes active, BD signal (HSYNC) from the LSU is not detected at the specified times (41 ± 10 times within 20msec).
Cause			LSU connector disconnection or LSU's inside harness disconnection or breakage Polygon motor rotation abnormality Improper positioning of the laser home position sensor in the LSU. Laser power voltage failure Laser emitting diode abnormality MCU PWB abnormality

Main code	Sub code		Detail of trouble	
E7	03	Check and remedy	Improper connection of the LSU connector Check the polygon motor operation with SIM 25-10. Check printing with SIM64-1. Check laser emission of laser emitting diode. Check the LSU unit. Check the MCU PWB.	
		04	Content	CCD white level trouble
			Detail	CCD white reference level which is read during the copy lamp lighting is abnormal.
			Cause	Flat cable installation failure to CCD unit Dirt on the mirror, lens, and reference white plate Copy lamp lighting failure CCD unit installation failure CCD unit abnormality MCU PWB abnormality
			Check and remedy	Clean the mirror, the lens, and the reference white plate. Check the copy lamp (SIM 5-3) ON. Carriage unit position failure Check the sub scanning direction distortion adjustment (F rail height). CCD unit check MCU PWB check
		05	Content	CCD black level trouble
	Detail		CCD black level which is read while the copy lamp is off is abnormal.	
	06	Content	Shifter motor trouble	
		Details	The home position is not detected within 1 sec after shifter motor drive.	
	06	Cause	The shifter home position sensor is defective. The shifter motor is defective. The shifter motor periphery circuit is defective. The condition of the MCU PWB JP4 is wrong. The assembly of the shifter motor unit is improper.	
		Check and remedy	Check the shifter operation by means of SIM3-2 and 3. Check the harnesses and connectors. Check whether the shifter unit is properly assembled. Check whether the condition of the MCU PWB JP4 is correct.	

Main code	Sub code		Detail of trouble
F2	04	Content	CRUM data read trouble
		Detail	Communication error between CRUM PWB and MCU PWB
		Cause	CRUM PWB data error MCU PWB error MCU PWB EEPROM error Disconnection between CRUM (toner cartridge) and MCU PWB
		Check and remedy	Replace the toner cartridge. Replace MCU PWB. Replace MCU PWB EEPROM Check and fix connection between CRUM (toner cartridge) and MCU PWB.
F5	02	Content	Copy lamp error
		Detail	Copy lamp voltage detection error
		Cause	Power unit trouble Copy lamp trouble Inverter trouble MCU PWB trouble
		Check and remedy	Replace the power unit. Check the copy lamp ON with SIM 5-3. Replace the copy lamp. Replace the inverter. Replace the MCU PWB.
F6	00	Content	Communication trouble between MCU and FAX (MCU detection)
		Detail	Communication establishment error, framing error, parity error, protocol error
		Cause	Bad connection of FAX control PWB connector Defective harness between FAX control PWB and MCU PWB. Motherboard connector pin breakage FAX control PWB ROM error, data error
		Check and remedy	Check connector/harness of FAX control PWB and MCU PWB. Check grounding of the machine. Check FAX control PWB ROM.
	10	Content	FAX control PWB trouble
		Detail	Communication trouble between MCU and FAX control WPB
		Cause	Bad connection of FAX control PWB connector Defective harness between FAX control PWB and MCU PWB Motherboard connector pin breakage FAX control PWB ROM error/Data error
		Check and remedy	Check connector/harness between FAX control PWB and MCU PWB. Check grounding of the machine. Check FAX control PWB ROM.
	80	Content	FAX control PWB communication trouble (Protocol)
		Detail	Communication trouble between MCU and FAX control PWB (Protocol error)

Main code	Sub code		Detail of trouble	
F6	80	Cause	Bad connection of FAX control PWB connector Defective harness between FAX control PWB and MCU PWB Motherboard connector pin breakage FAX control PWB ROM error/Data error	
		Check and remedy	Check connector/harness between FAX control PWB and MCU PWB. Check grounding of the machine. Check FAX control PWB ROM.	
		81	Content	FAX control PWB communication trouble (Parity)
			Detail	Communication trouble between MCU and FAX control PWB (Parity error)
	81	Cause	Bad connection of FAX control PWB connector Defective harness between FAX control PWB and MCU PWB Motherboard connector pin breakage FAX control PWB ROM error/Data error	
		Check and remedy	Check connector/harness between FAX control PWB and MCU PWB. Check grounding of the machine. Check FAX control PWB ROM.	
	82	Content	FAX control PWB communication trouble (Overrun)	
		Detail	Communication trouble between MCU and FAX control PWB (Overrun error)	
		Cause	Bad connection of FAX control PWB connector Defective harness between FAX control PWB and MCU PWB Motherboard connector pin breakage FAX control PWB ROM error/Data error	
		Check and remedy	Check connector/harness between FAX control PWB and MCU PWB. Check grounding of the machine. Check FAX control PWB ROM.	
	84	Content	FAX control PWB communication trouble (Framing)	
		Detail	Communication trouble between MCU and FAX control PWB (Framing error)	
Cause		Bad connection of FAX control PWB connector Defective harness between FAX control PWB and MCU PWB Motherboard connector pin breakage FAX control PWB ROM error/Data error		
Check and remedy		Check connector/harness between FAX control PWB and MCU PWB. Check grounding of the machine. Check FAX control PWB ROM.		

Main code	Sub code		Detail of trouble
F6	88	Content	FAX control PWB communication trouble (Timeout)
		Detail	Communication trouble between MCU and FAX control PWB (Timeout error)
		Cause	Bad connection of FAX control PWB connector Defective harness between FAX control PWB and MCU PWB Motherboard connector pin breakage FAX control PWB ROM error/Data error
		Check and remedy	Check connector/harness between FAX control PWB and MCU PWB. Check grounding of the machine. Check FAX control PWB ROM.
F9	00	Content	Communication trouble between MCU and printer PWB (MCU detection)
		Detail	Communication establishment error, framing error, parity error, protocol error
		Cause	Bad connection of printer PWB connector Defective harness between printer PWB and MCU PWB. Motherboard connector pin breakage Printer PWB ROM error, data error
		Check and remedy	Check connector/harness of printer PWB and MCU PWB. Check grounding of the machine. Check printer PWB ROM.
	10	Content	Printer PWB trouble
		Detail	Communication trouble between MCU and printer PWB
		Cause	Bad connection of printer PWB connector Defective harness between printer PWB and MCU PWB. Motherboard connector pin breakage Printer PWB ROM error, data error
		Check and remedy	Check connector/harness of printer PWB and MCU PWB. Check grounding of the machine. Check printer PWB ROM.
	80	Content	Printer PWB communication trouble (Protocol)
		Detail	Communication trouble between MCU and printer PWB (Protocol error)
		Cause	Bad connection of printer PWB connector Defective harness between printer PWB and MCU PWB. Motherboard connector pin breakage Printer PWB ROM error, data error
		Check and remedy	Check connector/harness of printer PWB and MCU PWB. Check grounding of the machine. Check printer PWB ROM.

Main code	Sub code		Detail of trouble
F9	81	Content	Printer PWB communication trouble (Parity)
		Details	Communication trouble between MCU and printer PWB(Parity error)
		Cause	Printer PWB connector disconnection Printer PWB MCU PWB harness failure Printer PWB mother board connector pin breakage. Printer PWB ROM defect,data failure
		Check and remedy	Check the connectors and harness of the printer PWB and the MCU PWB. Check grounding of the machine. Check the ROM of the printer PWB.
	82	Content	Printer PWB communication trouble (Overrun)
		Details	Communication trouble between MCU and printer PWB(Overrun error)
		Cause	Printer PWB connector disconnection Printer PWB MCU PWB harness failure Printer PWB mother board connector pin breakage. Printer PWB ROM defect,data failure
		Check and remedy	Check the connectors and harness of the printer PWB and the MCU PWB. Check grounding of the machine. Check the ROM of the printer PWB.
	84	Content	Printer PWB communication trouble (Framing)
		Details	Communication trouble between MCU and printer PWB(Framing error)
		Cause	Printer PWB connector disconnection Printer PWB MCU PWB harness failure Printer PWB mother board connector pin breakage. Printer PWB ROM defect,data failure
		Check and remedy	Check the connectors and harness of the printer PWB and the MCU PWB. Check grounding of the machine. Check the ROM of the printer PWB.
88	Content	Printer PWB communication trouble (Time-out)	
	Details	Communication trouble between MCU and printer PWB(Time-out error)	

Main code	Sub code		Detail of trouble
F9	88	Cause	Printer PWB connector disconnection Printer PWB MCU PWB harness failure Printer PWB mother board connector pin breakage. Printer PWB ROM defect,data failure
		Check and remedy	Check the connectors and harness of the printer PWB and the MCU PWB. Check grounding of the machine. Check the ROM of the printer PWB.
H2	00	Content	Thermistor open detection
		Detail	Fusing thermistor open
		Cause	Thermistor defect MCU PWB defect Fusing section connector contact failure Power supply failure Fusing unit not installed
		Check and remedy	Check the harness and the connector of the thermistor and the MCU. Clear the self diag display with SIM 14.
H3	00	Content	Heat roller abnormally high temperature
		Detail	Fusing temperature of 220 ~ 240°C.
		Cause	Thermistor defect MCU PWB defect Fusing connector connection failure Power supply failure
		Check and remedy	Check the heater lamp blinking with SIM 5-2. When the lamp blinks normally: Check the thermistor and the harness. Check the MCU PWB thermistor input circuit. When the lamp lights up instead of blinking: Check the lamp control circuit of the power supply PWB and the MCU PWB. Clear the trouble with SIM 14.
H4	00	Content	Heat roller abnormally low temperature
		Detail	When the temperature does not reach 155°C within 55 sec after turning on the power, or when it falls under 145°C during printing, or when it falls under 100°C during pre-heating.
		Cause	Thermistor failure Heater lamp failure MCU PWB failure Thermostat failure Power supply failure Interlock switch failure

Main code	Sub code		Detail of trouble
H4	00	Check and remedy	Check blinking of the heater lamp with SIM 5-2. When the lamp blinks normally: Check the thermistor and the harness. Check the MCU PWB thermistor input circuit. When the lamp does not light: Check for heater lamp disconnection or thermostat disconnection. Check the interlock switch. Check the power supply PWB and MCU PWB lamp control circuit. Clear the trouble with SIM 14.
		L1	00
L1	00	Detail	The mirror home position (MHPS) does not turn off though the feed operation is completed during mirror initial operation after turning on the power. The mirror home position (MHPS) does not turn off during shading operation. The mirror home position (MHPS) does not turn on when the mirror base is returned for the specified time after copy feed is started and SPF scanning position shift is performed.
		Cause	Mirror unit defect Mirror home position sensor defect MCU PWB defect Scanner wire disconnection
		Check and remedy	Check the scanning operation with SIM 1-1.
		L3	00
L3	00	Detail	The mirror home position (MHPS) does not turn on though the mirror base returning is completed during mirror initial operation after turning on the power. The mirror home position does not turn on when the mirror is returned to the home position during shading. The mirror home position (MHPS) does not turn on when the mirror base returning is completed for the specified time (about 6 sec) after copy return start.
		Cause	Mirror unit Mirror home position sensor defect MCU PWB defect Scanner wire disconnection
		Check and remedy	Check the scanning operation with SIM 1-1.
L4	01	Content	Main motor lock
		Detail	The main motor encoder pulse is not detected for 400msec.
		Cause	Main motor defect Harness disconnection between the MCU PWB and the main motor. Control circuit failure

Main code	Sub code		Detail of trouble
L4	01	Check and remedy	Check the main motor operation with SIM 25-1. Check the harness and the connector between the MCU PWB and the main motor.
		10	Content
	10	Details	When the home is not detected within 2.5 sec after the job separator tray starts to move upwards.
		Cause	The job separator upper limit detection sensor is defective. The job separator motor is defective. The job separator motor periphery circuit is defective. The condition of the MCU PWB JP5 is wrong.
L6	10	Check and countermeasure	Check the job separator operation by means of SIM3-2 and 4. Check the harnesses and connectors. Check whether the condition of the MCU PWB JP5 is correct.
		Content	Polygon motor lock
L8	01	Detail	The lock signal (the specified rotation speed signal) is not supplied within the specified time (about 6 sec) after starting the polygon motor rotation.
		Cause	LSU connector disconnection or harness disconnection in the LSU.
		Check and remedy	Check the operation of the polygon motor with SIM 25-10. Check the harness and the connector connection. LSU replacement
U2	04	Content	EEPROM serial communication error
		Detail	Error in communication with EEPROM
		Cause	EEPROM failure Installation of uninitialized EEPROM MCU PWB EEPROM access circuit failure
		Check and remedy	Check that the EEPROM is properly set. To prevent against loss of counter/adjustment values, record the values with simulation. U2 trouble cancel with SIM 16 MCU PWB replacement

Main code	Sub code		Detail of trouble
U2	11	Content	Counter check sum error
		Detail	Counter check sum value stored in the EEPROM is abnormal.
		Cause	EEPROM failure Control circuit hung up by noises MCU PWB EEPROM access circuit defect
		Check and remedy	Check that the EEPROM is properly set. To prevent against loss of counter/adjustment values, record the values with simulation. U2 trouble cancel with SIM 16 MCU PWB replacement
	12	Content	Adjustment value check sum error (EEPROM)
		Detail	Adjustment value data area check sum error
		Cause	EEPROM failure Control circuit hung up by noises MCU PWB EEPROM access circuit failure
		Check and remedy	Check that the EEPROM is properly set. To prevent against loss of counter/adjustment values, record the values with simulation. U2 trouble cancel with SIM 16 MCU PWB replacement
	40	Content	CRUM communication error
		Detail	Toner cartridge CRUM data read error
		Cause	A toner cartridge of a different destination is installed. EEPROM trouble Check the destination setup. Toner cartridge CRUM PWB trouble MCU PWB trouble CRUM connector disconnection
	U3	29	Check and remedy
Content			Mirror base home position error
Detail			Home position is not detected when starting mirror base shift.
Cause			Mirror unit defect Mirror home position sensor defect MCU PWB defect Scanner wire disconnection
U9	00	Check and remedy	Check the scanning operation with SIM 1-1.
		Content	Communication trouble between MCU and OPE (OPE detection)
		Detail	Communication setup error, framing, parity, protocol error

Main code	Sub code		Detail of trouble
U9	00	Cause	Operation control PWB connector disconnection Operation control PWB MCU PWB harness failure
		Check and remedy	Check the connectors and harness of the operation control PWB and the MCU PWB. Check grounding of the machine. Check the ROM of the operation control PWB.
	80	Content	Operation control PWB communication trouble (Protocol)
		Detail	Communication trouble between MCU and the operation control PWB (Protocol error)
		Cause	Operation control PWB connector disconnection Operation control PWB MCU PWB harness failure
		Check and remedy	Check the connectors and harness of the operation control PWB and the MCU PWB. Check grounding of the machine.
	81	Content	Operation control PWB communication trouble (Parity)
		Detail	Communication trouble between MCU and the operation control PWB (Parity error)
		Cause	Operation control PWB connector disconnection Operation control PWB MCU PWB harness failure
		Check and remedy	Check the connectors and harness of the operation control PWB and the MCU PWB. Check grounding of the machine.
	82	Content	Operation control PWB communication trouble (Overrun)
		Detail	Communication trouble between MCU and the operation control PWB (Overrun error)
		Cause	Operation control PWB connector disconnection Operation control PWB MCU PWB harness failure
		Check and remedy	Check the connectors and harness of the operation control PWB and the MCU PWB. Check grounding of the machine.
	84	Content	Operation control PWB communication trouble (Framing)
		Detail	Communication trouble between MCU and the operation control PWB (Framing error)
		Cause	Operation control PWB connector disconnection Operation control PWB MCU PWB harness failure
		Check and remedy	Check the connectors and harness of the operation control PWB and the MCU PWB. Check grounding of the machine.

Main code	Sub code		Detail of trouble
U9	88	Content	Operation control PWB communication trouble (Time-out)
		Detail	Communication trouble between MCU and the operation PWB (Time-out error)
		Cause	Operation control PWB connector disconnection Operation control PWB MCU PWB harness failure
		Check and remedy	Check the connectors and harness of the operation control PWB and the MCU PWB. Check grounding of the machine.
U95		Content	Operation control PWB communication error
		Detail	Communication error between the operation control PWB and the MCU PWB (Detected by the OPE-PWB)
		Cause	Disconnection or reverse connection of the flat cable between the Operation control PWB and the MCU PWB. Operation control PWB trouble MCU PWB trouble Connector trouble of the operation control PWB and the MCU PWB
		Check and remedy	Check insertion of or replace the flat cable between the operation control PWB and the MCU PWB. Replace the operation control PWB. Replace the MCU PWB. Check connection of the connector of the operation control PWB and the MCU PWB.
U99		Content	Operation control PWB communication error
		Detail	Communication error between the operation control PWB and the MCU PWB (Detected by the OPE-PWB)
		Cause	Disconnection or reverse connection of the flat cable between the Operation control PWB and the MCU PWB. Operation control PWB trouble MCU PWB trouble Connector trouble of the operation control PWB and the MCU PWB
		Check and remedy	Check insertion of or replace the flat cable between the operation control PWB and the MCU PWB. Replace the operation control PWB. Replace the MCU PWB. Check connection of the connector of the operation control PWB and the MCU PWB.

[10] MAINTENANCE

1. Maintenance table

X: Check (Clean, adjust, or replace when required.) : Clean ▲: Replace : Adjust ☆: Lubricate

Unit name	Part name		When calling or replacing the kit	150k
Transfer section		Charger unit	○	○
		Transfer paper guide	○	○
Optical section	Lamp unit	Reflector	○	○
		Mirror	○	○
	No. 2/3 mirror unit	Mirror	○	○
		Pulley	×	×
	CCD peripheral	Lens	○	○
	Glass	Table glass	○	○
		White plate	○	○
	Other	Drive wire	×	×
		Rail	×☆	×☆
		Document cover	○	○
Document size sensor		○	○	
LSU		Dust-proof glass	○	○
Paper feed section	Multi paper feed section	Takeup roller	○	○
		Paper feed roller	○	○
		Spring clutch	○☆	○☆
	Cassette section	Paper feed roller	○	○
		Spring clutch	○☆	○☆
Paper transport section		PS roller	○	○
		Transport (paper exit) rollers	○	○
		Spring clutch	○☆	○☆
Fusing section		Upper heat roller	○	▲
		Pressure roller	○	○
		Pressure roller bearing	×	○☆
		Upper separation pawl	×	○
		Lower separation pawl	×	○
Drive section		Gears	×☆	×☆
		Belts	×	○
Paper exit section		Ozone filter	×	× *1

*1: Recommendable replacement time: 30K (A4 (8.5" × 11"), 6% print)

2. Maintenance display system

Toner	Life	13K	
	Remaining quantity check *1	a. Press and hold the density adjustment LIGHT key for more than 5 sec, and the machine will enter the user program mode. b. Press and hold the "%" key for more than 5 sec, and the remaining quantity will be displayed on the copy quantity display in one of the following levels: (Remaining quantity display levels: 100%, 75%, 50%, 25%, 10%, LO) c. Press the density adjustment LIGHT key to cancel.	
	Remaining quantity	NEAR EMPTY About 10%	EMPTY
	LED	ON	Flash
	Machine	Operation allowed	Stop
Developer	Life	30K	
	LED	ON at 30K of the developer count.	
	Machine	Selection is available between Not Stop and Stop by Service Simulation (SIM 26-37) Setup. (If Stop is selected, the LED will flash and stop at 30K.) * Default: Not Stop * Clear: SIM 42-1	
Maintenance	LED	Selection is available among 30K, 15K, 10K, 7.5K, 5K, and free (no lighting) with SIM 21-1. * Default: 30K * Clear: SIM 20-1	
	Machine	Not stop.	

*1: Installation of a new toner cartridge allows to display the remaining quantity.

3. Note for replacement of consumable parts

A. Toner cartridge

When a waste toner cartridge is removed from the machine, it must be put in a polyethylene bag to avoid scattering of toner.

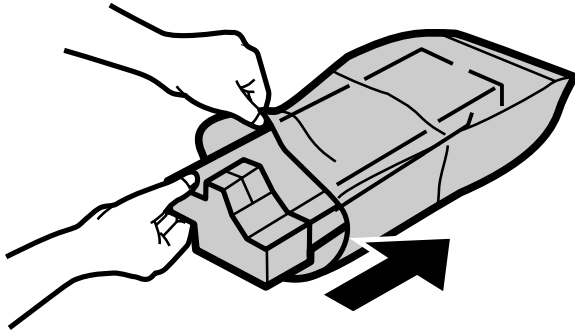

B. DV cartridge

Do not shake or put up the developer cartridge. Otherwise developer may scatter.

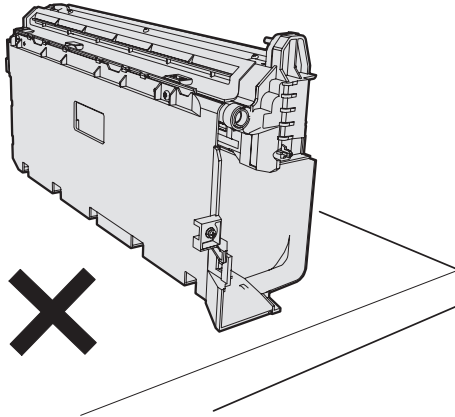

[11] DISASSEMBLY AND ASSEMBLY

WARNING: Before performing the disassembly procedure, be sure to remove the power cord to prevent against an electric shock.

No.	Item
1	High voltage section/Duplex transport section
2	Optical section
3	Fusing section
4	Paper exit section
5	MCU
6	Optical frame unit
7	LSU
8	Tray paper feed section/Paper transport section
9	Manual multi paper feed section
10	Power section
11	Developing section
12	Process section

1. High voltage section/Duplex transport section

No.	Content
A	Transfer charger unit
B	Charger wire
C	Duplex transport section <Only AR-206/207>

A. Transfer charger unit

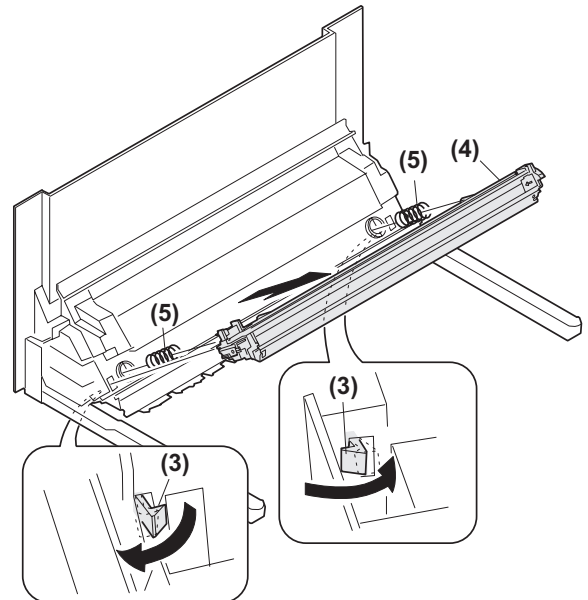
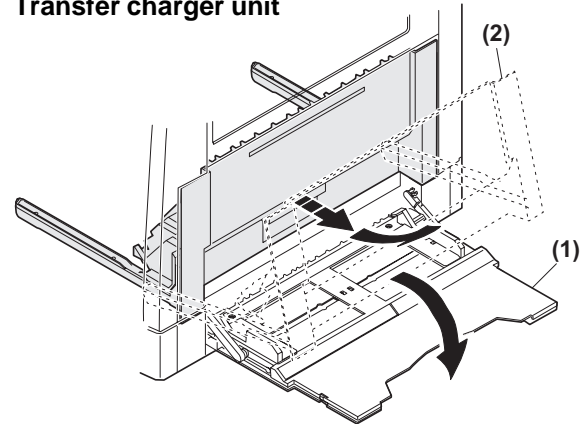

B. Charger wire

Installation: The spring tip must be between two reference ribs.

- The charger wire must be free from twist or bending.
- Be sure to put the charger wire in the V groove.

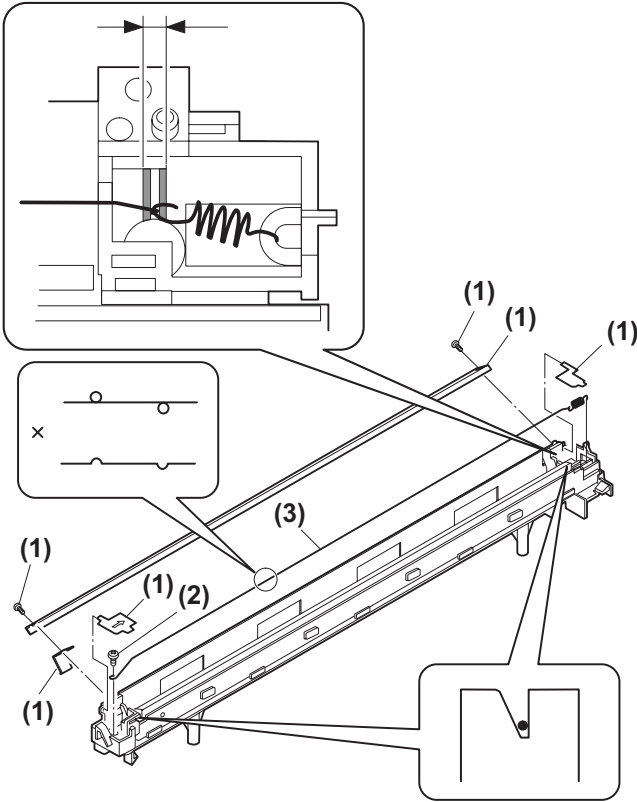

C. Duplex transport section <Only AR-206/207>

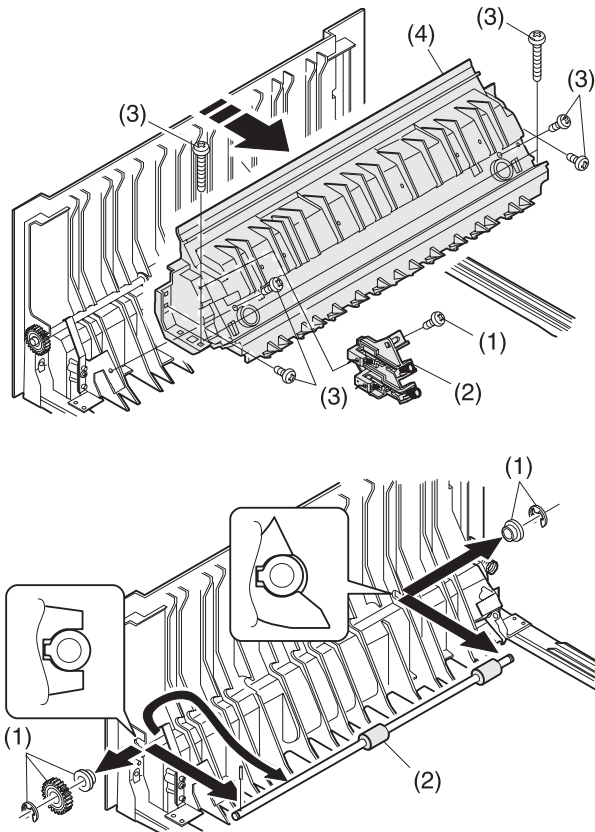

2. Optical section

No.	Content
A	Table glass
B	Copy lamp unit
C	Copy lamp
D	Lens unit

A. Table glass

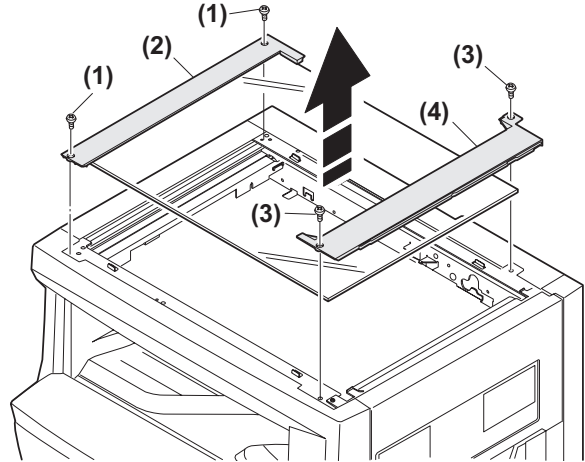

B. Copy lamp unit

Disassembly: Be sure to put No. 2/3 mirror unit to the positioning plate (A).

Assembly: Put the notched surface of wire holder (3) downward, tighten temporarily, and install.

Adjustment: Main scanning direction distortion balance adjustment

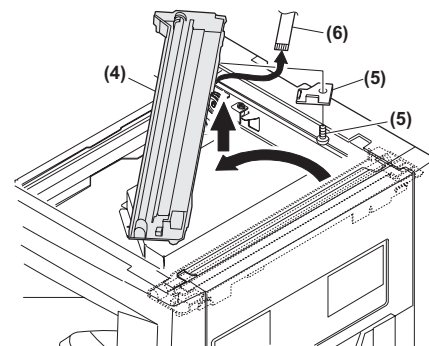
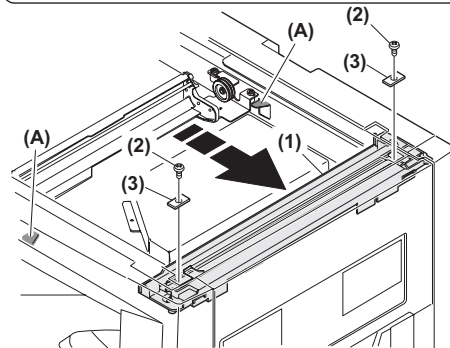
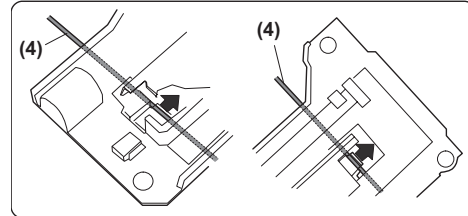

C. Copy lamp

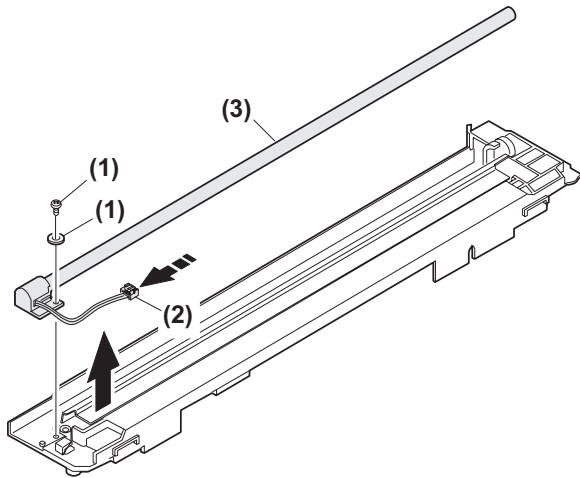

D. Lens unit

Note: Do not remove screws which are not indicated in the figure. If the height of the base plate is changed, it cannot be adjusted in the market.

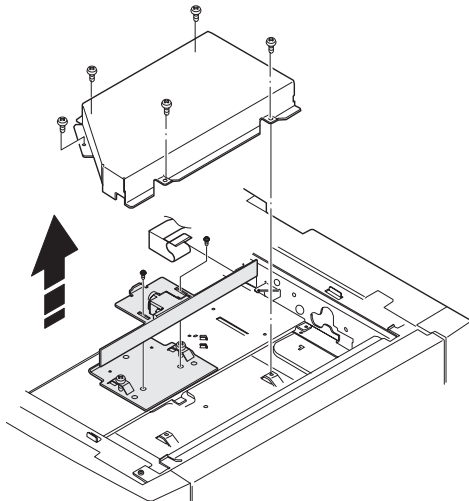

Lens unit attachment reference

Attach the lens unit so that the lens unit number on the lens adjustment plate is aligned with the scribe line on the base plate.

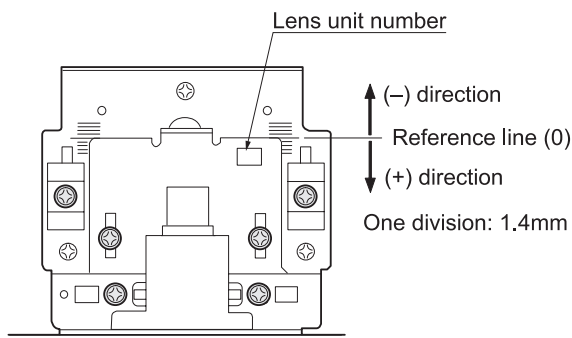

Example: Lens unit number -2.8
Attach the lens unit at 2 scales in the paper exit direction from the reference line.

Note: Never touch the other screws than the unit attachment screw.
The lens unit is supplied only in a whole unit.

3. Fusing section

No.	Contents
A	Fusing unit
B	Thermostat
C	Thermistor
D	Heater lamp
E	Upper heat roller
F	Separation pawl
G	Lower heat roller

A. Fusing unit removal

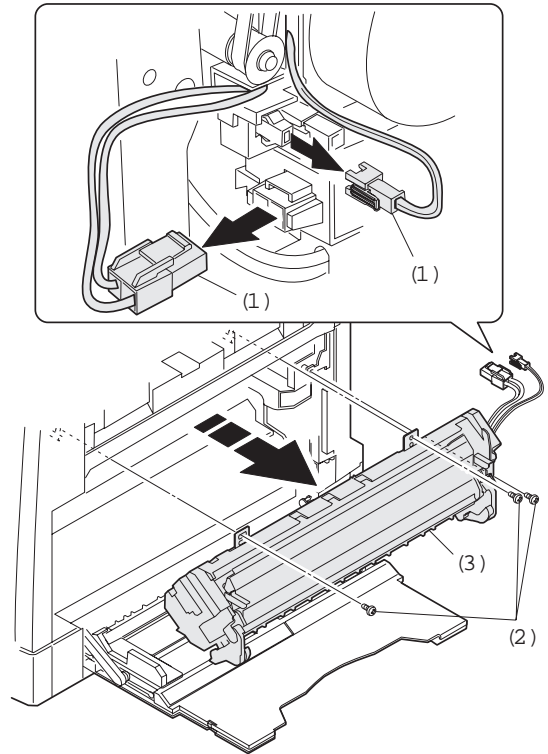

B. Thermostat

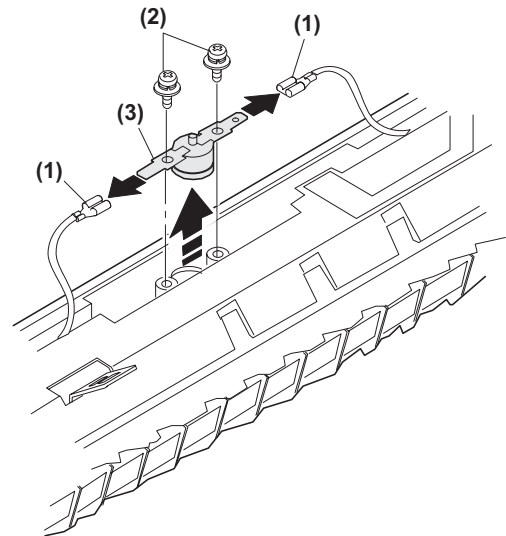

C. Thermistor

Installation: Check that the thermistor is in contact with the upper heat roller.

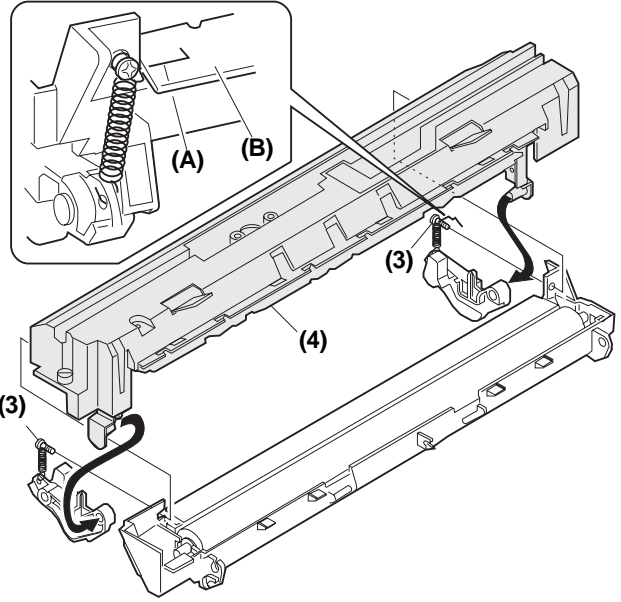
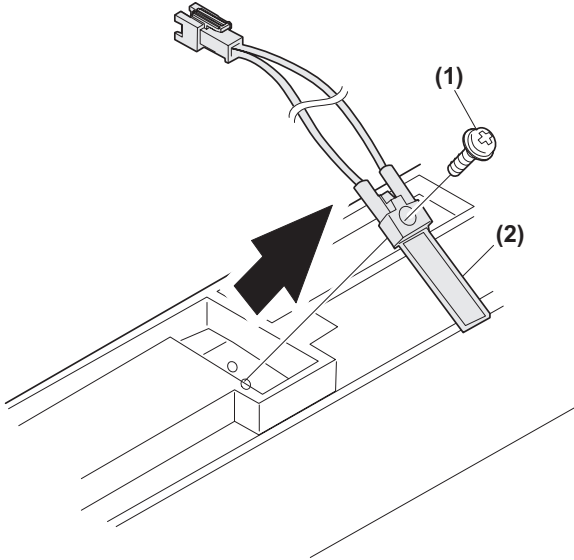

D. Heater lamp

Assembly: Insert the spring (A) into the hole (B) in the fusing frame.

Disassembly: There are three pawls on the fusing cover. Remove the screws and slide the fusing cover to the right to remove.

The heater lamp is fixed on the fusing cover with a screw. Slide the fusing cover to the front and remove the screw, then remove the heater lamp.

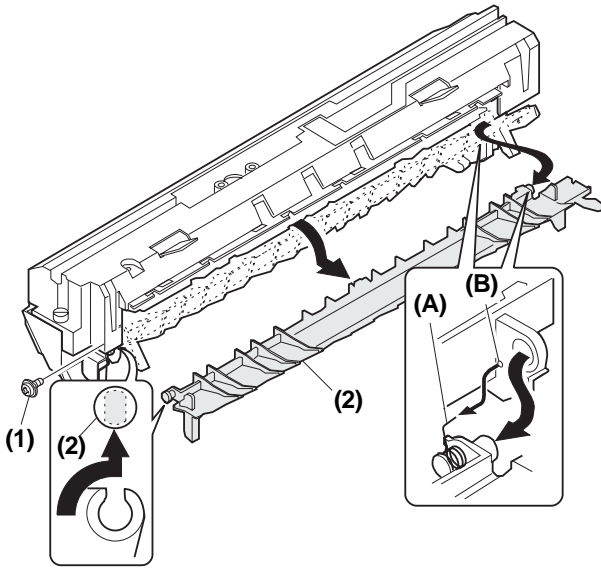

Assembly: Put the paper guide earth spring (A) under the paper guide (B) before fusing.

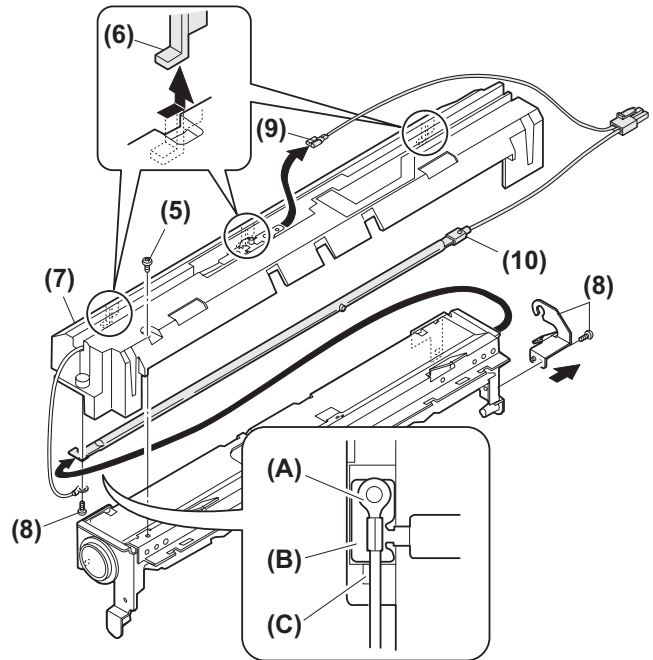

Assembly: Put the fusing harness (A) on the heater lamp (B) as shown in the figure and fix them together. Place the fusing harness inside the rib (C).

E. Upper heat roller

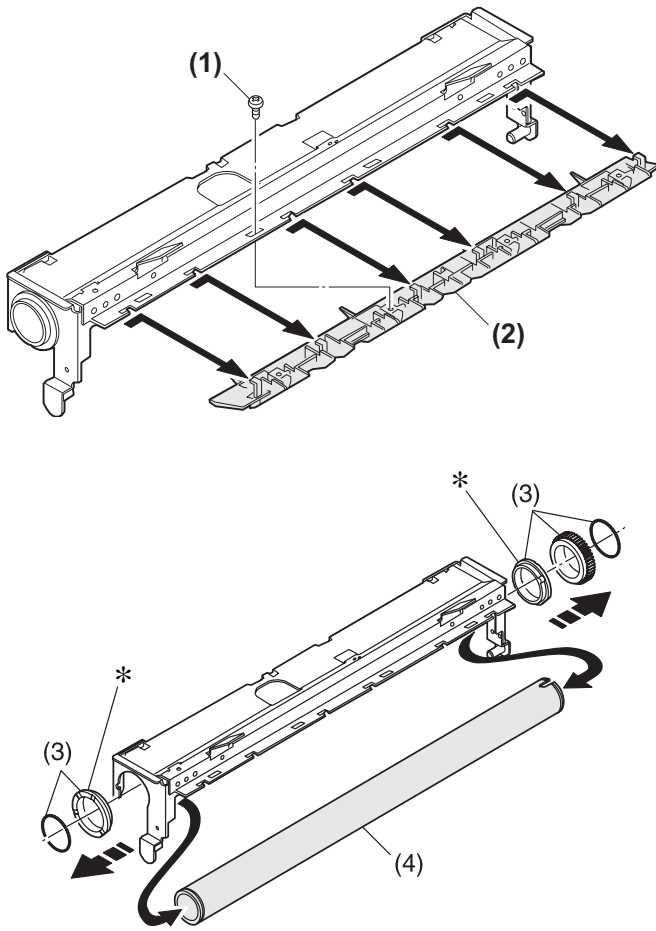

* Apply heat-resistant grease (UKOG-0235FCZZ).

F. Separation pawl

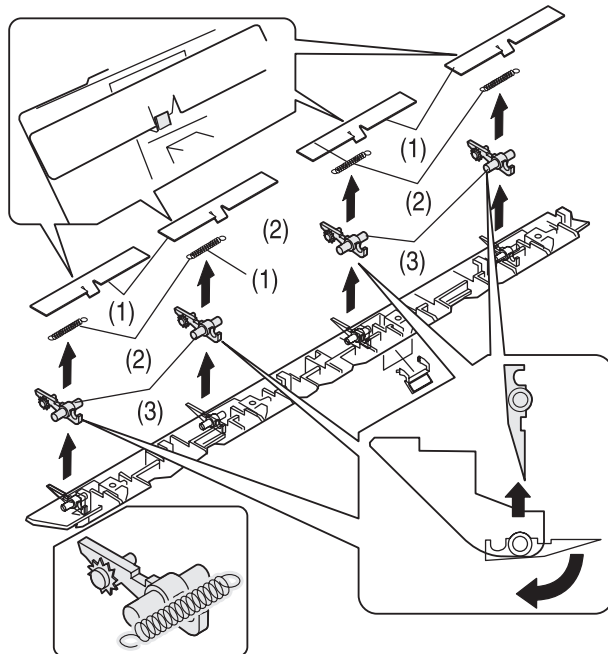

G. Lower heat roller

Assembly: When installing the paper guide (3) before fusing, tighten the paper guide fixing plate so that the paper guide fixing plate (2) is in contact with the frame bottom section (A) under fusing.

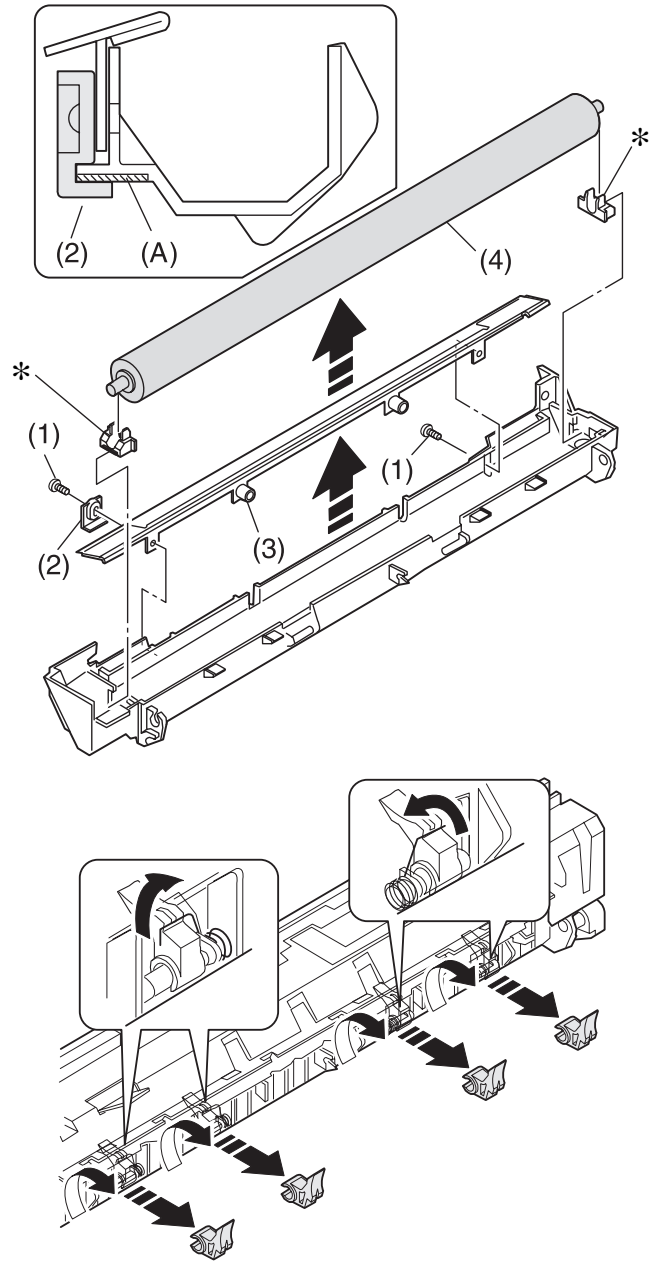

* Apply heat-resistant grease (UKOG-0235FCZZ).

4. Paper exit section

No.	Content
A	Front cabinet unit/Right cabinet unit
B	Ozone filter
C	Paper exit unit
D	Transport roller
E	Paper exit roller

A. Front cabinet unit, right cabinet disassembly

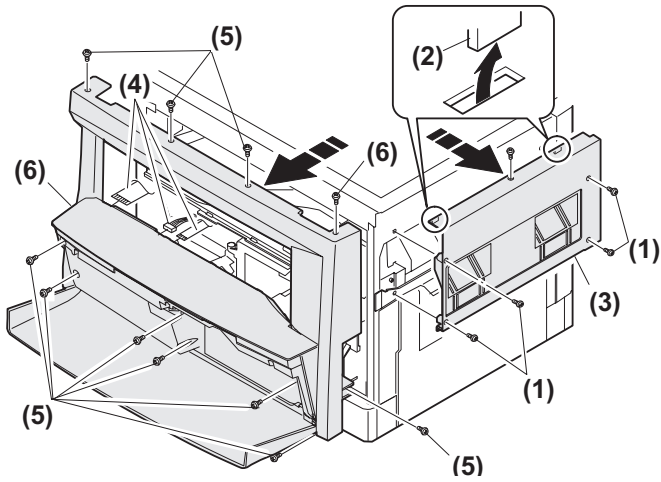

B. Ozone filter

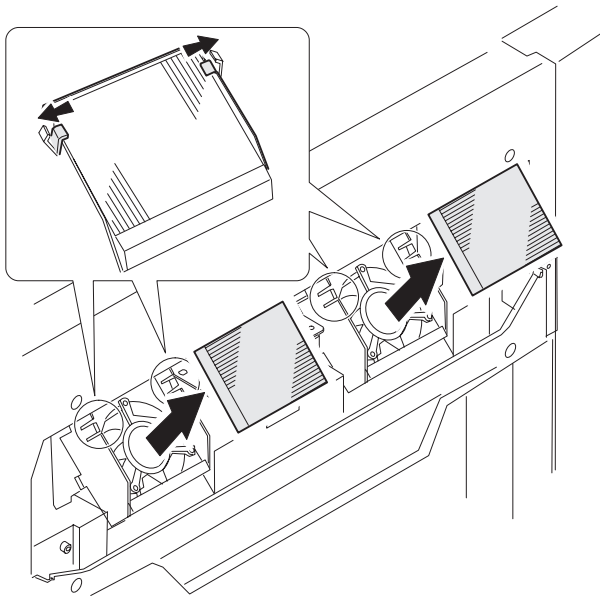

C. Paper exit unit

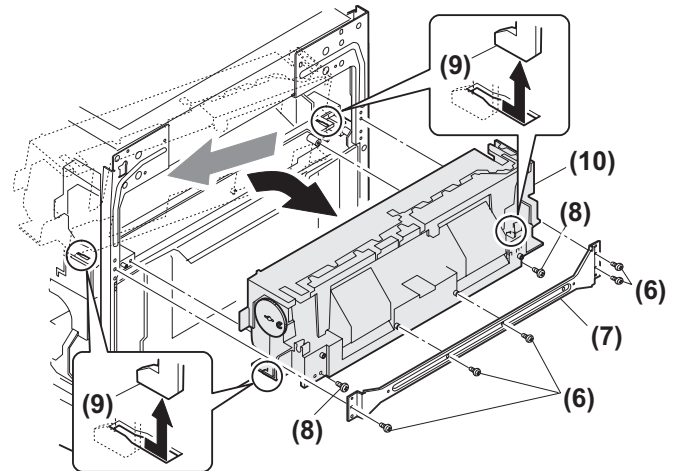
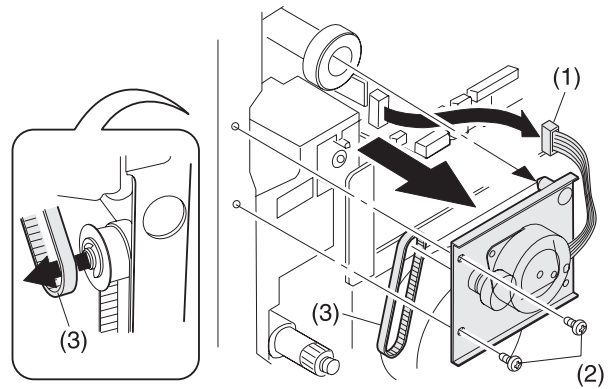

D. Transport roller

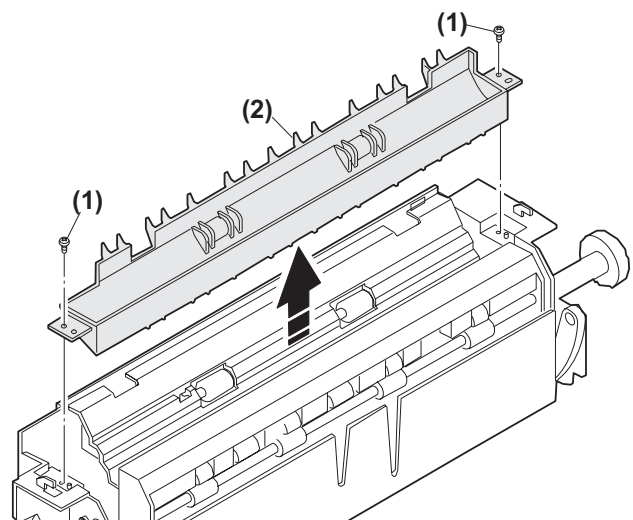

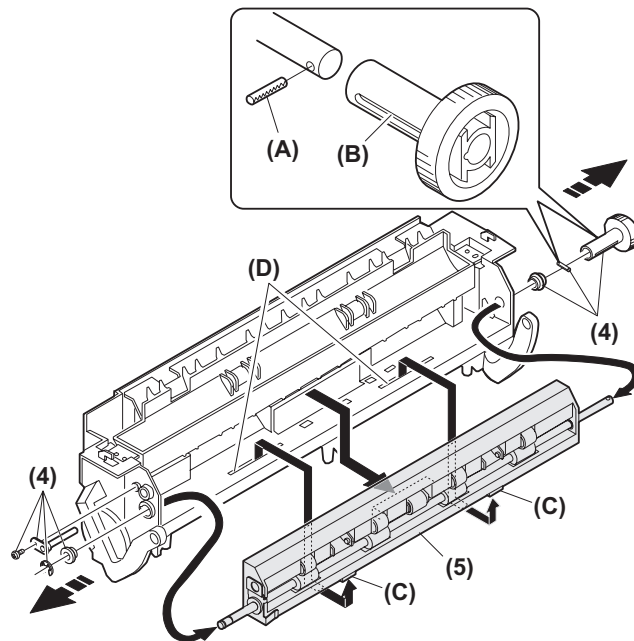
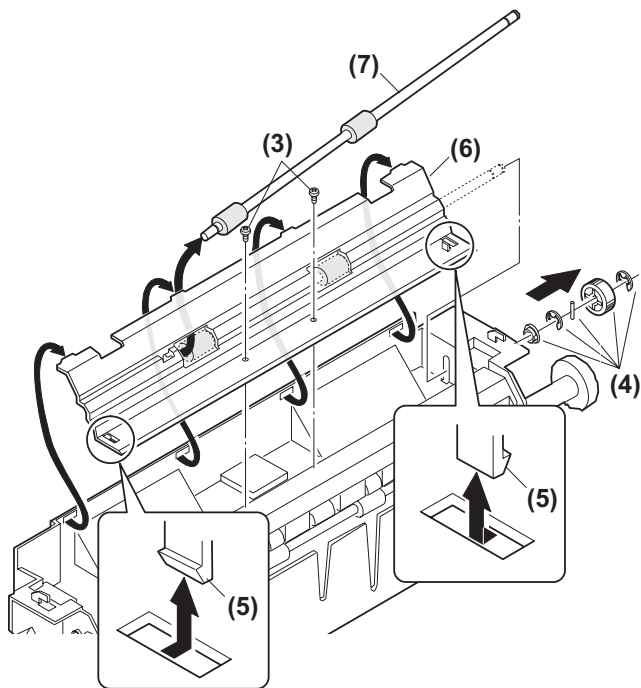

E. Paper exit roller

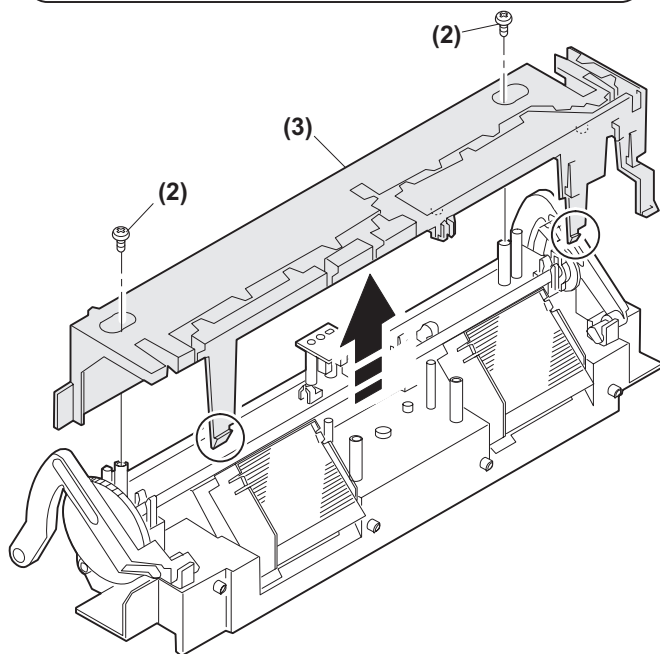
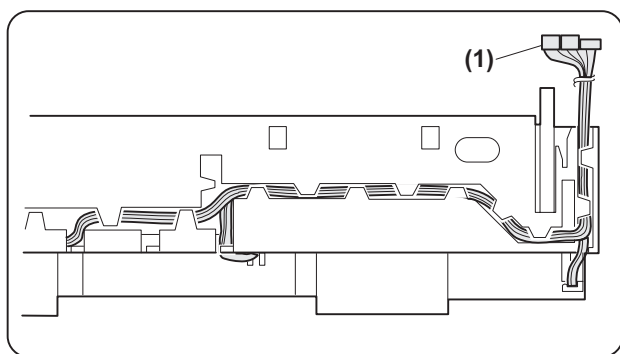

Assembly: Insert the spring pin so that the waveform (A) of the spring pin faces in the longitudinal direction of the paper exit drive gear long hole (B). Be sure to insert two ribs (C) into the groove (D).

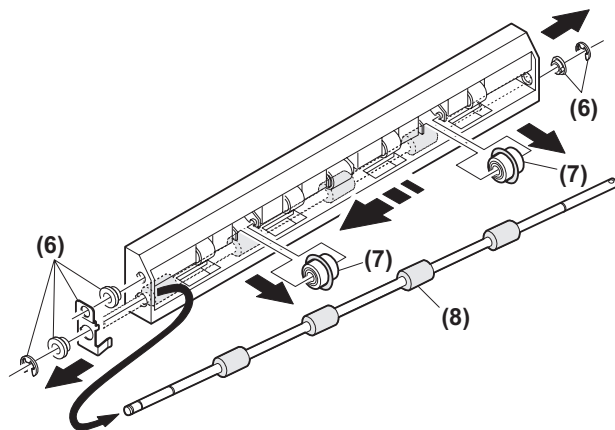

5. MCU

No.	Content
A	MCU

A. MCU disassembly

Note: When replacing the MCU PWB, be sure to replace the EEPROM of the MCU PWB to be replaced.

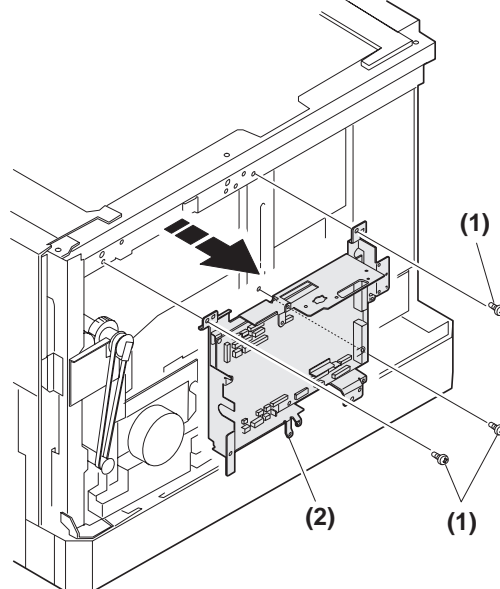

Note: When replacing the MCU PWB, be sure to restore the original jumper conditions.

<Reference: Factory setup>

			JP1	JP2	JP3	JP4	JP5	JP6	JP7	JP8
AB series	AR-162		○	○	○	○	○	○	○	○
	AR-163		○	○	○	×	○	○	○	○
	AR-163	SOPM	×	○	○	×	○	○	○	○
	AR-201		×	×	○	×	○	○	×	○
	AR-F201		×	×	○	×	×	○	×	○
	AR-206/207		×	×	×	×	○	○	×	×
Inch series	AR-162		○	○	○	○	○	○	○	○
	AR-163		○	○	○	×	○	○	○	○
	AR-163	SOPM	×	○	○	×	○	○	○	○
	AR-201		×	×	○	×	○	×	○	○
	AR-F201		×	×	○	×	×	○	○	○
	AR-206/207		×	×	×	×	○	×	○	×

○ : Jumper wire provided

×

6. Optical frame unit

No.	Content
A	Optical frame unit

A. Optical frame unit

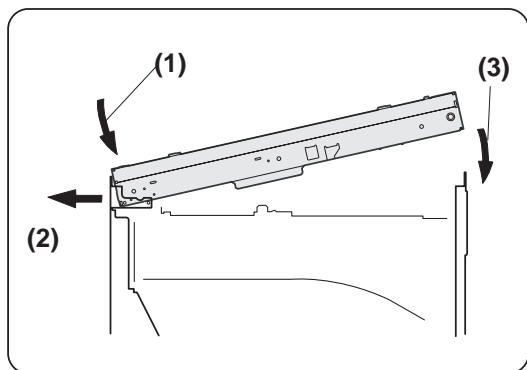
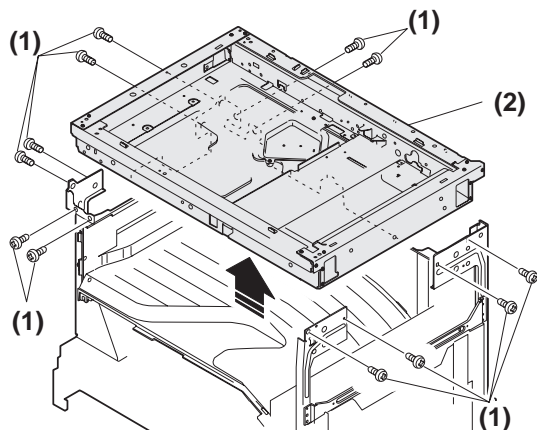

Installation: Install the optical unit in the sequence shown above.

7. LSU

No.	Content
A	LSU unit

A. LSU unit

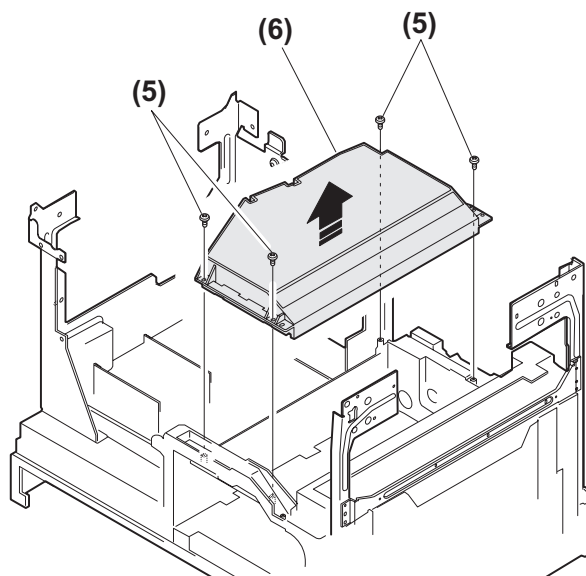
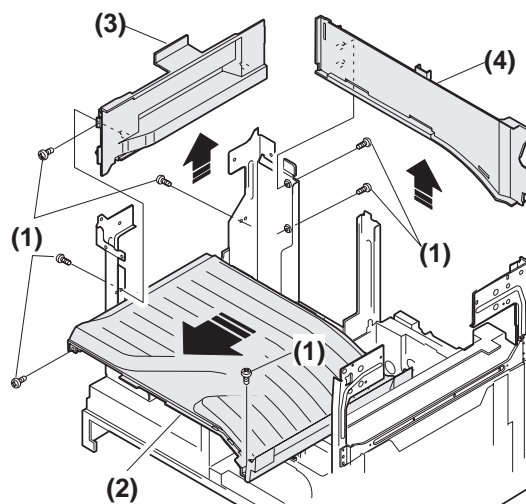

Note: Do not disassemble the LSU.

- Adjustment:
- Image lead edge position adjustment
 - Image left edge position adjustment
 - Paper off-center adjustment

8. Tray paper feed section/Paper transport section

No.	Content
A	Interface frame unit
B	Drive unit
C	Solenoid (paper feed solenoid, resist roller solenoid)
D	Resist roller clutch , Resist roller
E	Paper feed clutch/Paper feed roller (Semi-circular roller)

A. Intermittent frame unit

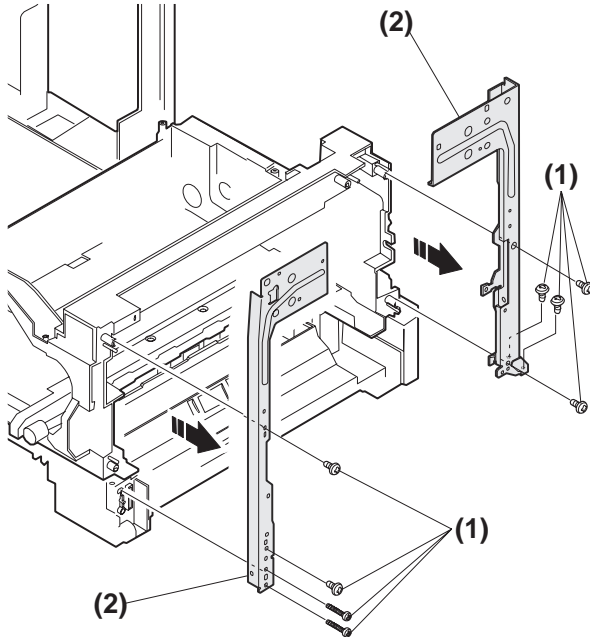

Assembly: Do not miss the door lock pawl.

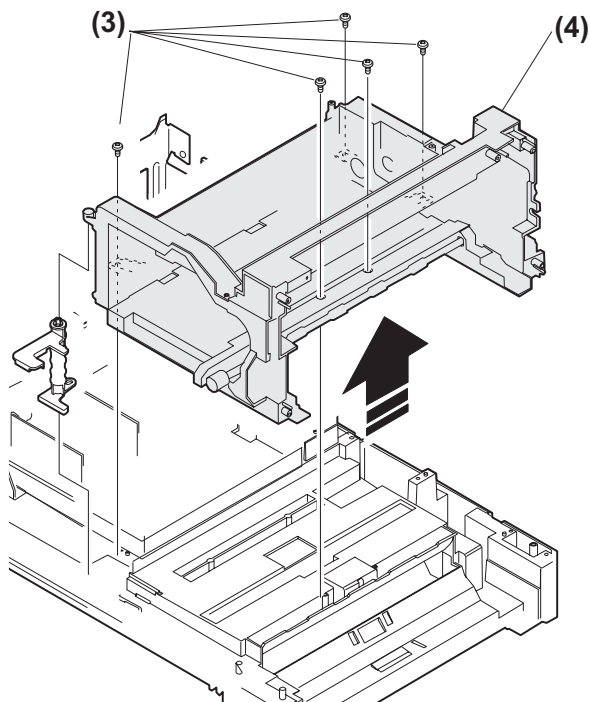

B. Drive unit

Assembly: Move down the clutch pawl as shown below, and avoid the clutch and install.

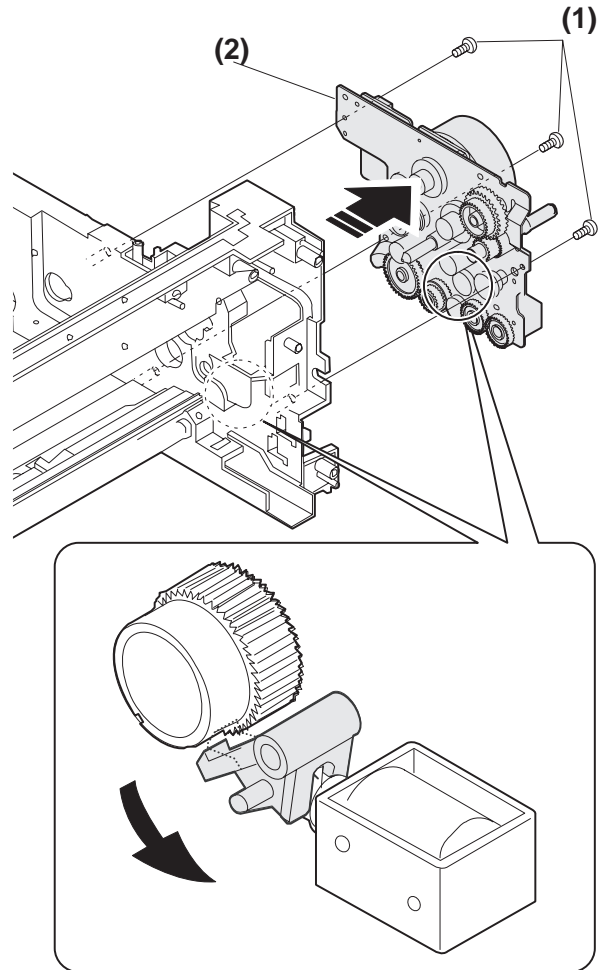

C. Solenoid (paper feed solenoid, resist roller solenoid)

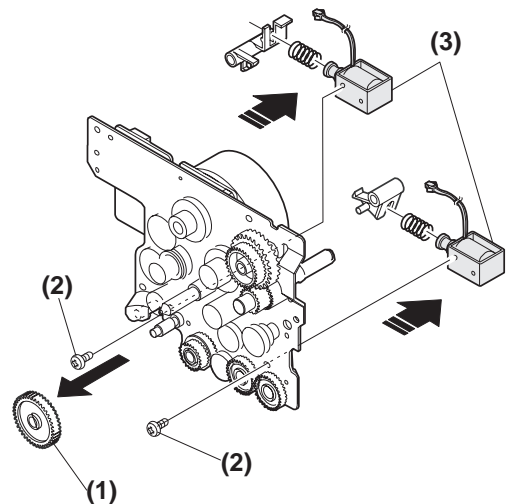

D. Resist roller clutch/Resist roller

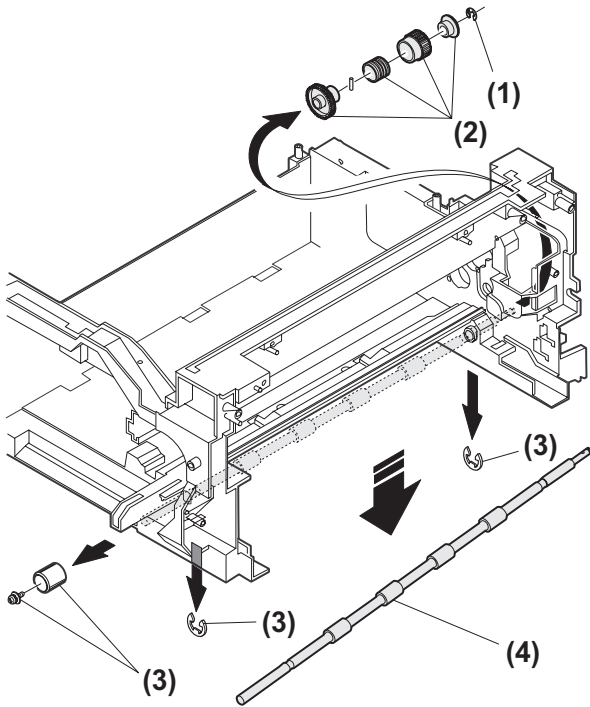

E. Paper feed clutch/Paper feed roller (Semi-circular roller)

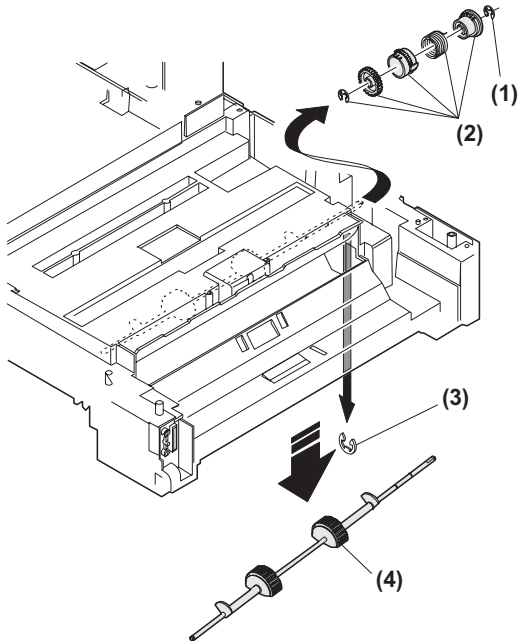

9. Manual multi paper feed section

No.	Content
A	Manual multi paper feed section
B	Manual transport clutch
C	Manual paper feed clutch
D	Manual transport roller/Manual paper feed roller
E	Multi feed solenoid

A. Manual multi paper feed

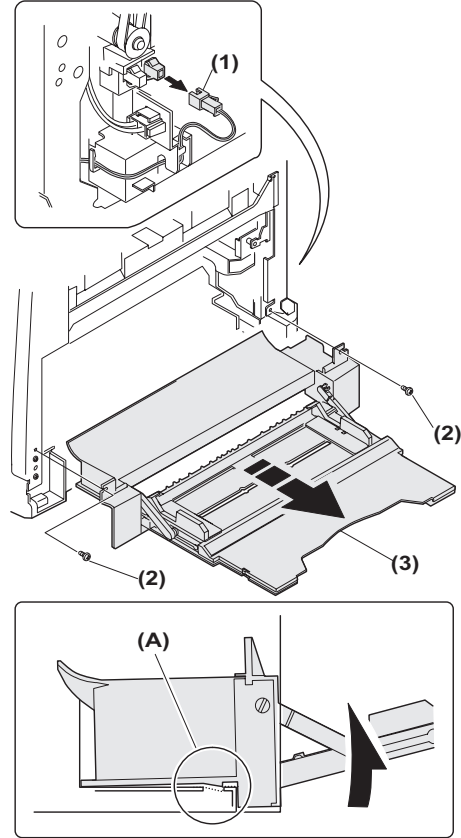

B. Manual transport clutch

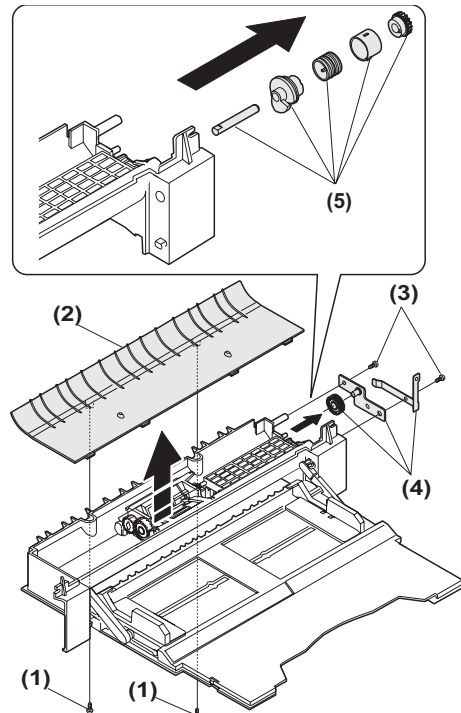

C. Manual paper feed clutch

Disassembly: Set up the shutter arm (1) then remove it.

Assembly: Install so that the boss section of the fulcrum arm (2) comes between ribs.

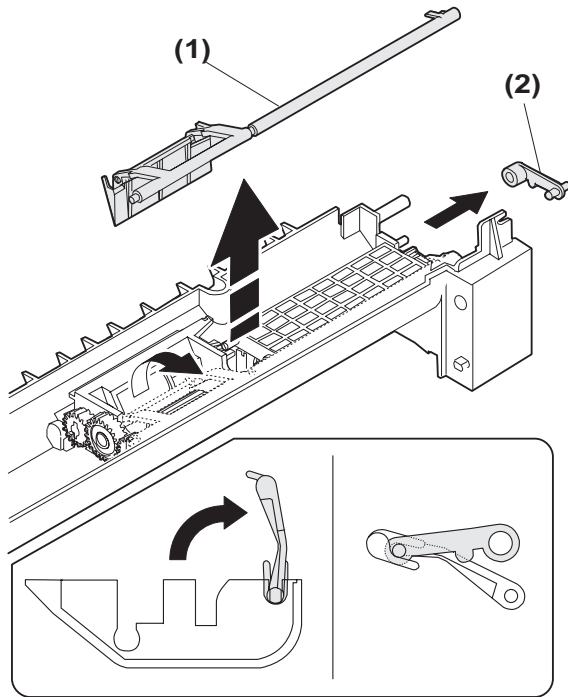

Disassembly: Set up the cam transmission arm (2), and remove it.

Assembly: Install so that the cam transmission arm (2) is under the roller arm (A).

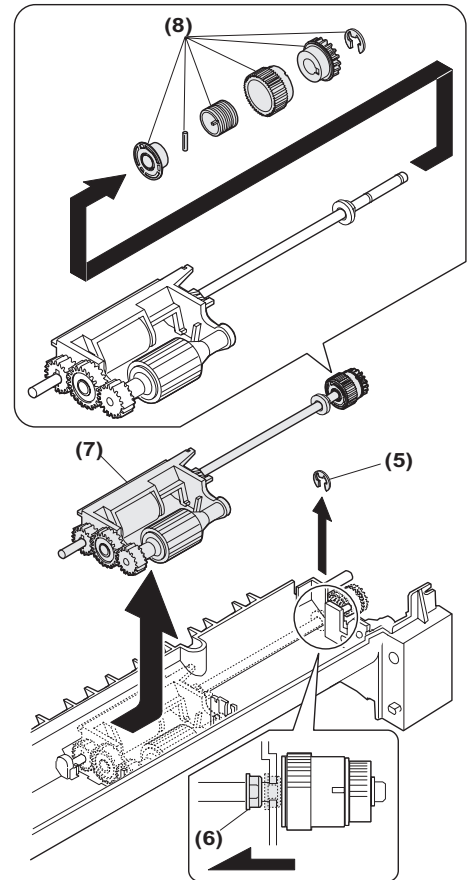
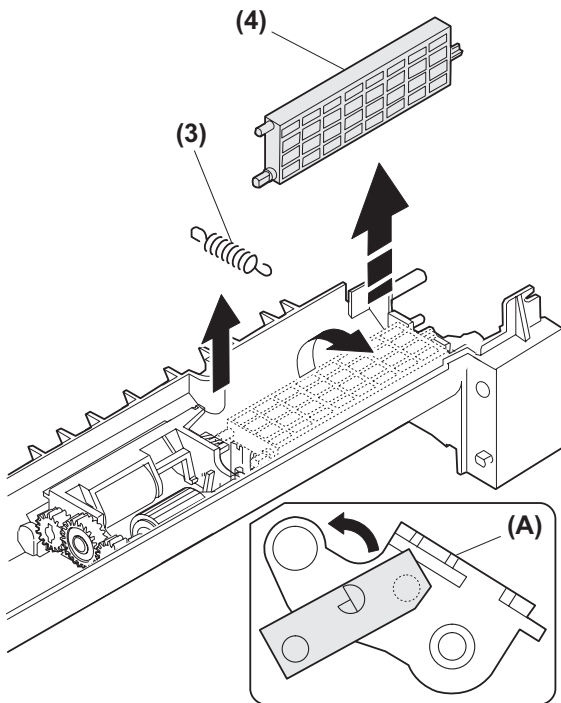

D. Manual transport roller/Manual paper feed roller

Installation: Be careful of the installing direction of the manual transport roller (4).

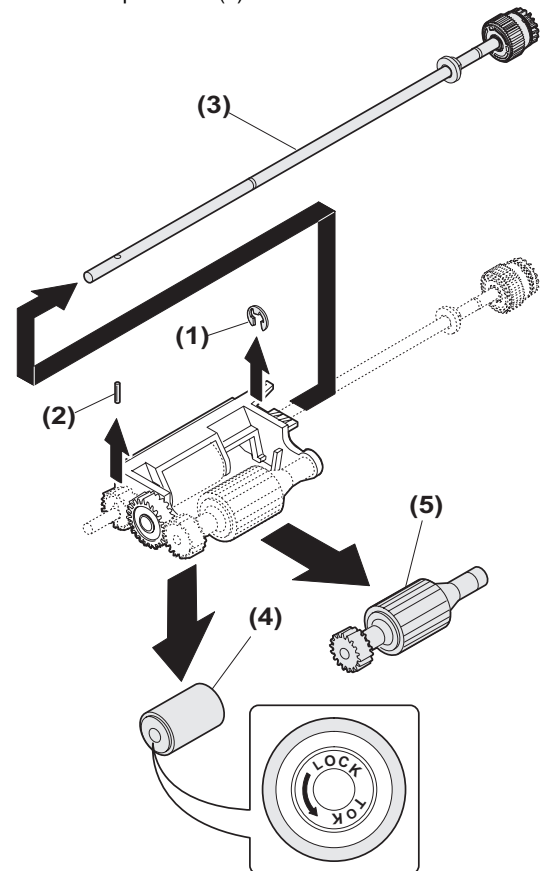

E. Multi feed solenoid

Assembly: Install so that the latches (A) and (B) move smoothly.

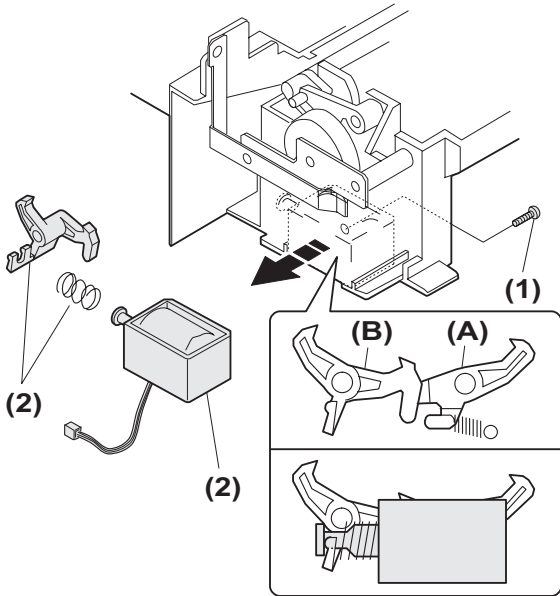

10. Power section

No.	Content
A	Power unit

A. Power unit

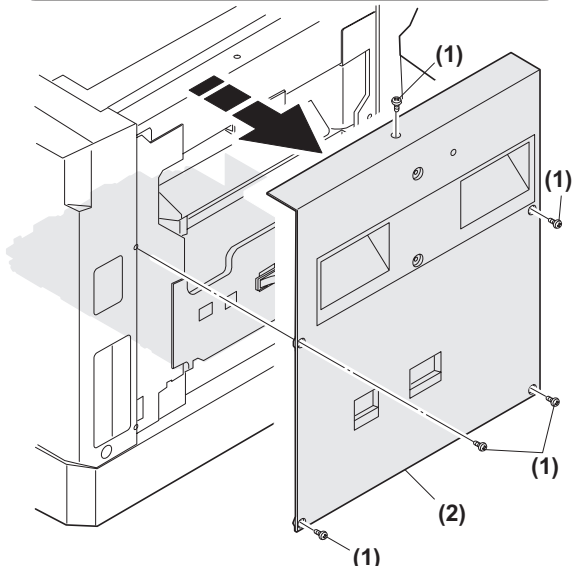
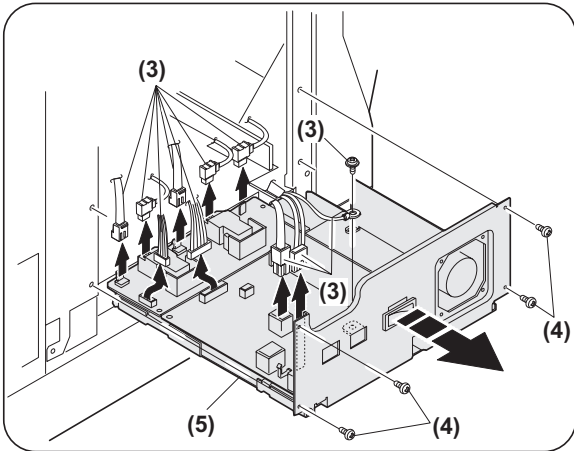

11. Developing section

No.	Contents
A	Developing box
B	Developing doctor
C	MG roller

A. Developing box

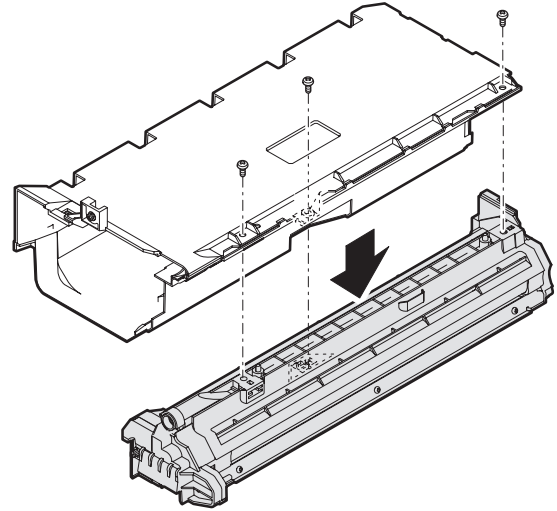

B. Developing doctor

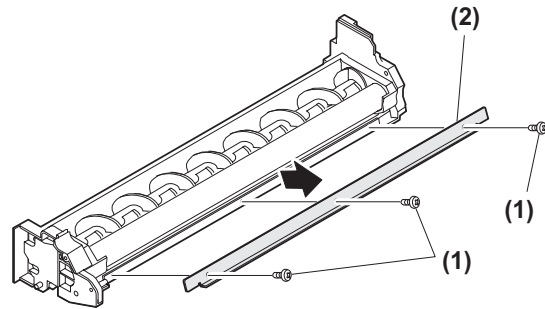

Adjustment: Developing doctor gap adjustment

C. MG roller

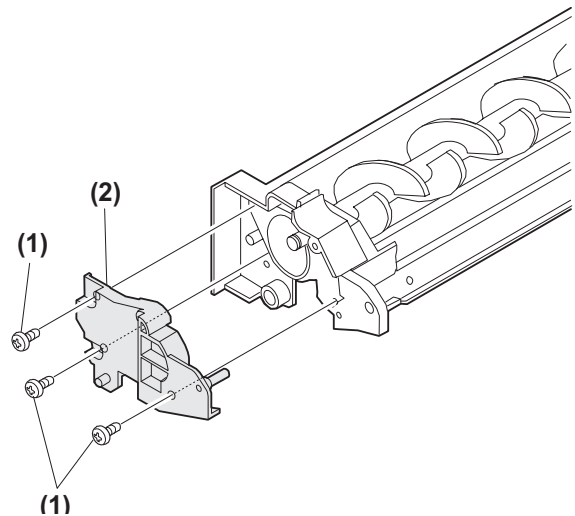

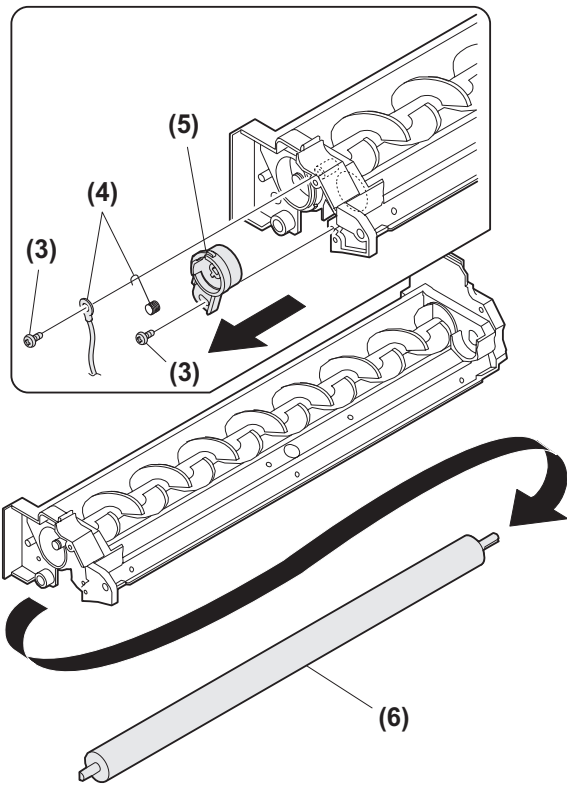

Adjustment: MG roller main pole position adjustment

12. Process section

No.	Contents
A	Drum unit
B	MC holder unit
C	Cleaning blade

A. Drum unit

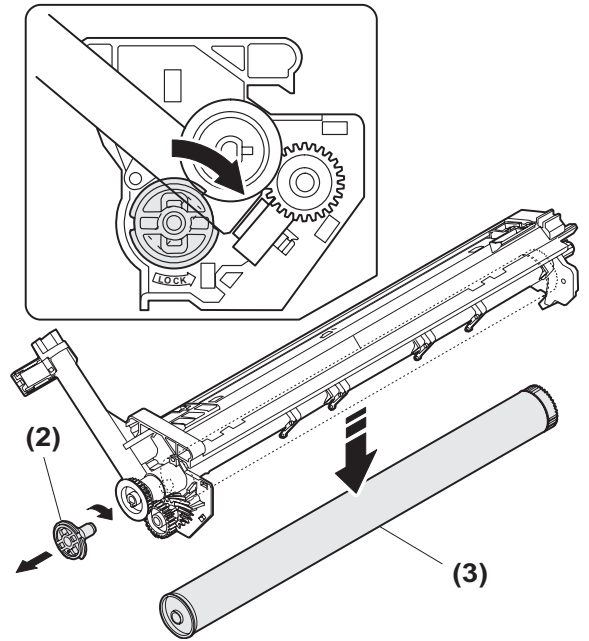
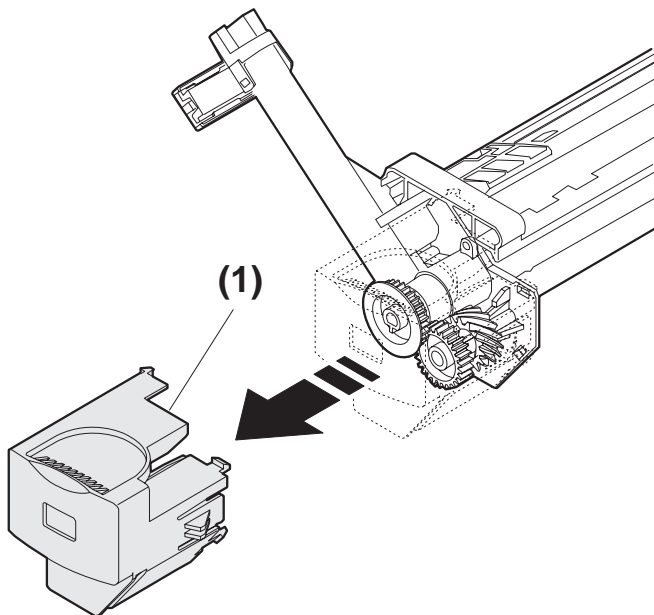

B. MC holder unit

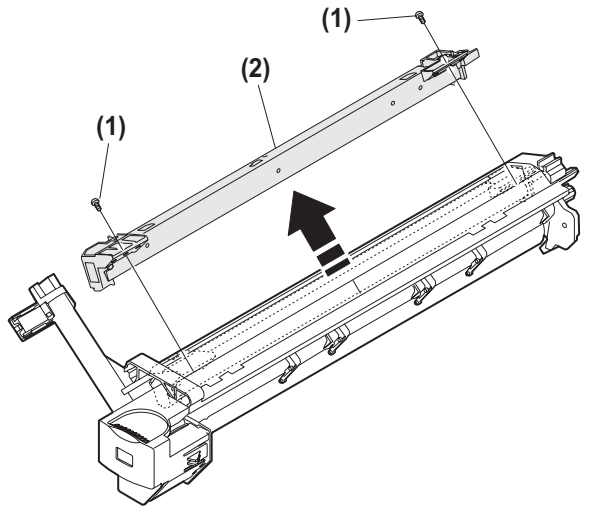

C. Cleaning blade

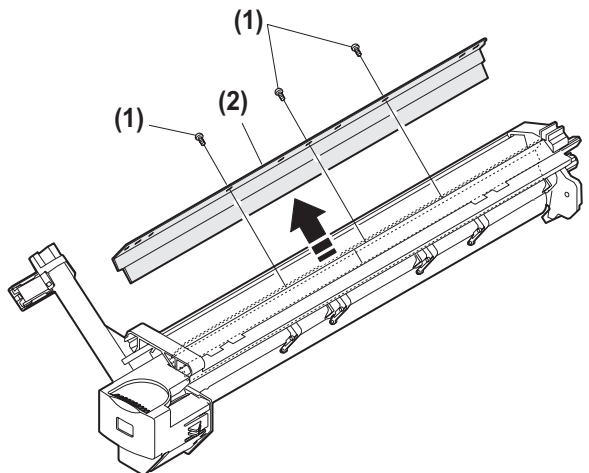

[12] FLASH ROM VERSION UP PROCEDURE

1. MCU/E-SORT

A. Tool

- Machine
- PC
 - Operates on Windows 95/98.
- Level converter (UKOG-0002QSZZ) (with serial cable)
- Level converter (UKOG-0003QSZZ) (without serial cable)
- (Serial cable)

B. Procedures

- 1) Connect the PC and the level converter, and start Windows.
- 2) Turn off the power of the machine.
- 3) Remove the cap at the rear of the machine.

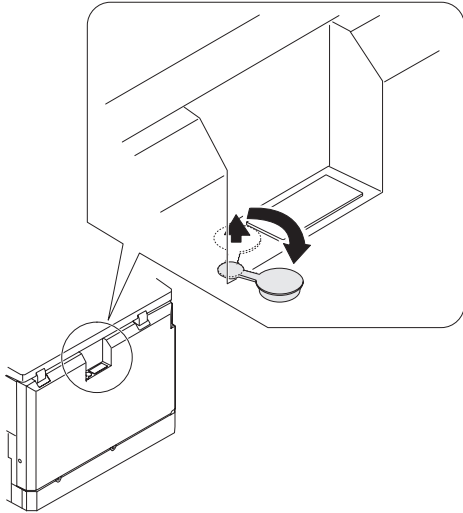

- 4) Connect the serial connector.

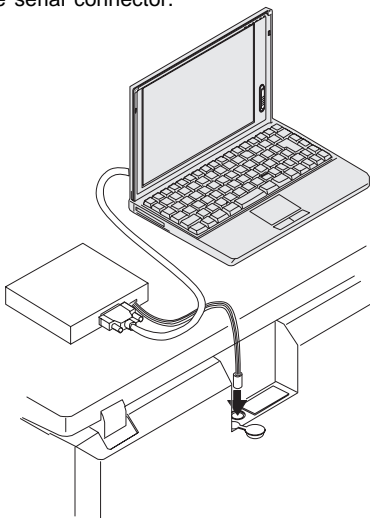

- 5) Turn on the power of the machine.
 - The machine enters the download mode. (All LED lamps are turned off. The machine accepts no key operations.)
- 6) Execute "mainte-Vxxx.exe" on the PC.



mainte_v1.06

Note Use "mainte_vxxx.exe" ver.1.06 or later.
 Since version 1.05 or before cannot identify the model (AR-162/163/201/206/207/F201), it may erroneously perform writing. In this case, the machine does not operate properly.

- 7) Communication port/communication speed setting
 - Select "Comport" in the option menu, and select the most suitable item with consideration of PC environment, work time, etc.

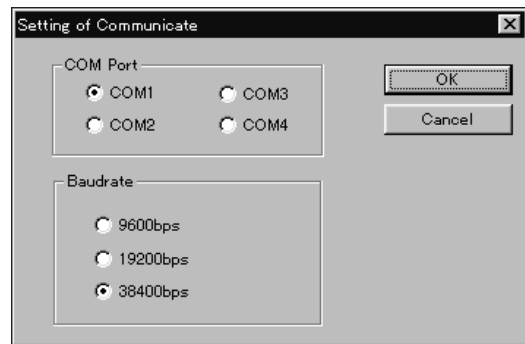
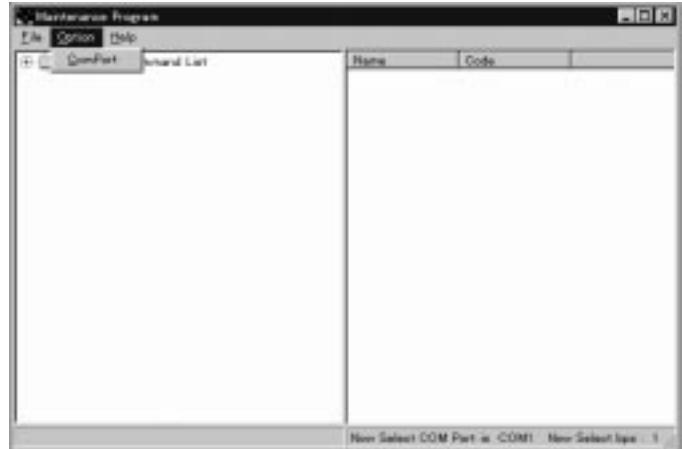

- 8) Select "Download the Program Data" in the SPECIAL folder, and transfer data.

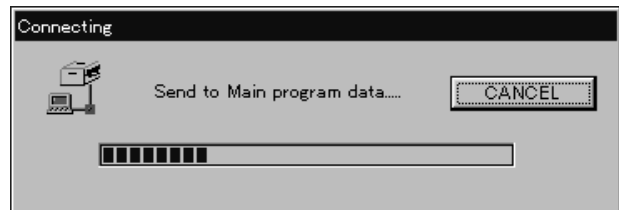

9) Select the data for MCU to be transferred.

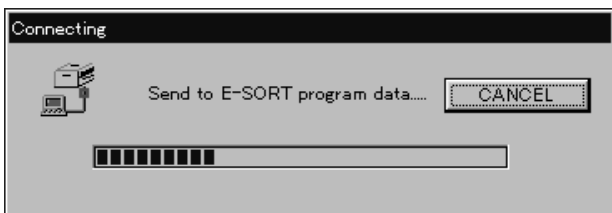

10) Select the data for the electronic sort board to be transferred.
 * When the electronic sort board is not installed, this procedure is automatically canceled. Go to procedure 11).

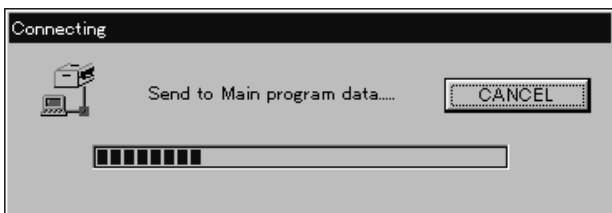

11) After transfer of data, turn off the machine and disconnect the connector.

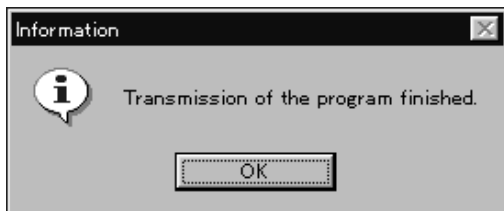

Reference: If the power is turned off during the procedure or in case of a communication error, resume the procedure from 2).



2. PRINTER CONTROL PWB FIRMWARE VERSION UP <With an option installed>

A. Cases where flash memory rewriting is required

In the following cases, the program in the printer control PWB flash memory must be rewritten.

- 1) When a bug or other error is found
- 2) Data stored in the flash memory is destroyed or deleted.
- 3) When the flash memory is replaced.

B. Necessary tools

- 1) Computer (PC) <Operates on MS-DOS.>
- 2) Parallel cable
- 3) Program data file (xxx.BIN)

C. Procedure

- 1) Print the configuration list to check the firmware version.
 Use the operation panel of the copier to perform the following procedure.
 ONLINE <off line> → MENU <Test Printing Menu> → ITEM <Configuration Page> → ENTER <The test page prints>
- 2) Connect the PC and the copier with the parallel cable.
- 3) Turn on the power
- 4) Execute SIM 67-14.
 "Erase Flash Data?" is displayed on the LCD.
- 5) Press the ENTER key on the copier's operation panel.
 "Now Erasing" is displayed on the LCD.
- 6) After deletion of data, "Please Send Data" is displayed on the LCD and the machine enters the ready state for data input.
- 7) Download the program file.

(Note) Never turn off the power during download.
 Set the PC to DOS mode → Check that the display shows READY. → Then type COPY _ /B _ xxx.BIN LPT1:
 and press the enter key.
 (_ : space)

- 8) The machine enters the data reception mode.
 While "Writing" is displayed on the LCD, data are written into the flash ROM.
- 9) When data reception and data writing into the flash ROM are completed, the SUM check is automatically performed.

(Note) In case of an error, "Sum check Error" is displayed.
 Turn off the power once, and repeat the procedures from 3).

- 10) If there is no problem on the result of the SUM check, "Complete" is displayed on the LCD.
- 11) Turn off/on the power to print the configuration page with the above procedures, and check the firmware version.
- 12) Perform printing on the PC side and check that printing is performed normally.

[13] ELECTRICAL SECTION

1. BLOCK DIAGRAM

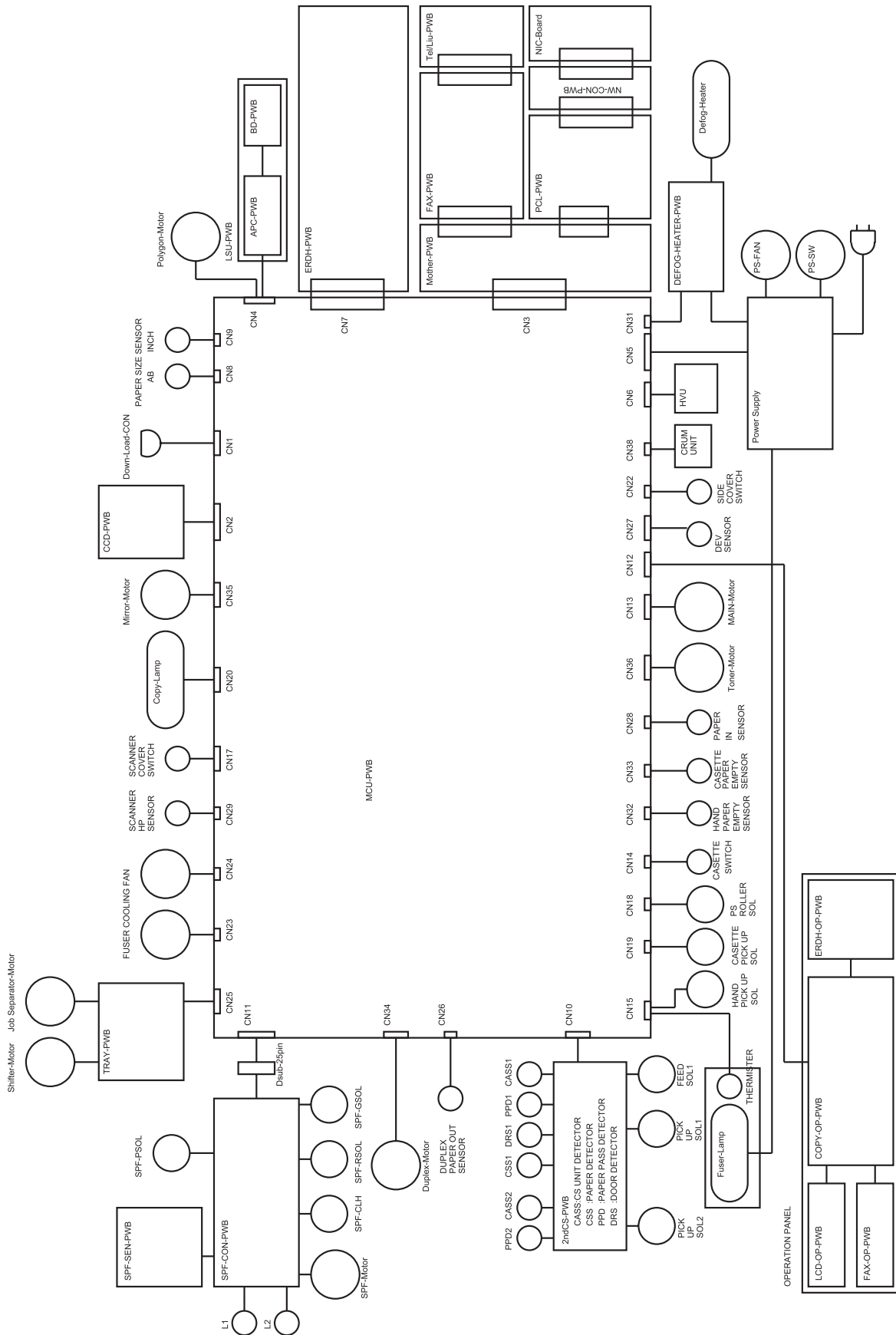

ACTUAL WIRING DIAGRAM 3/3

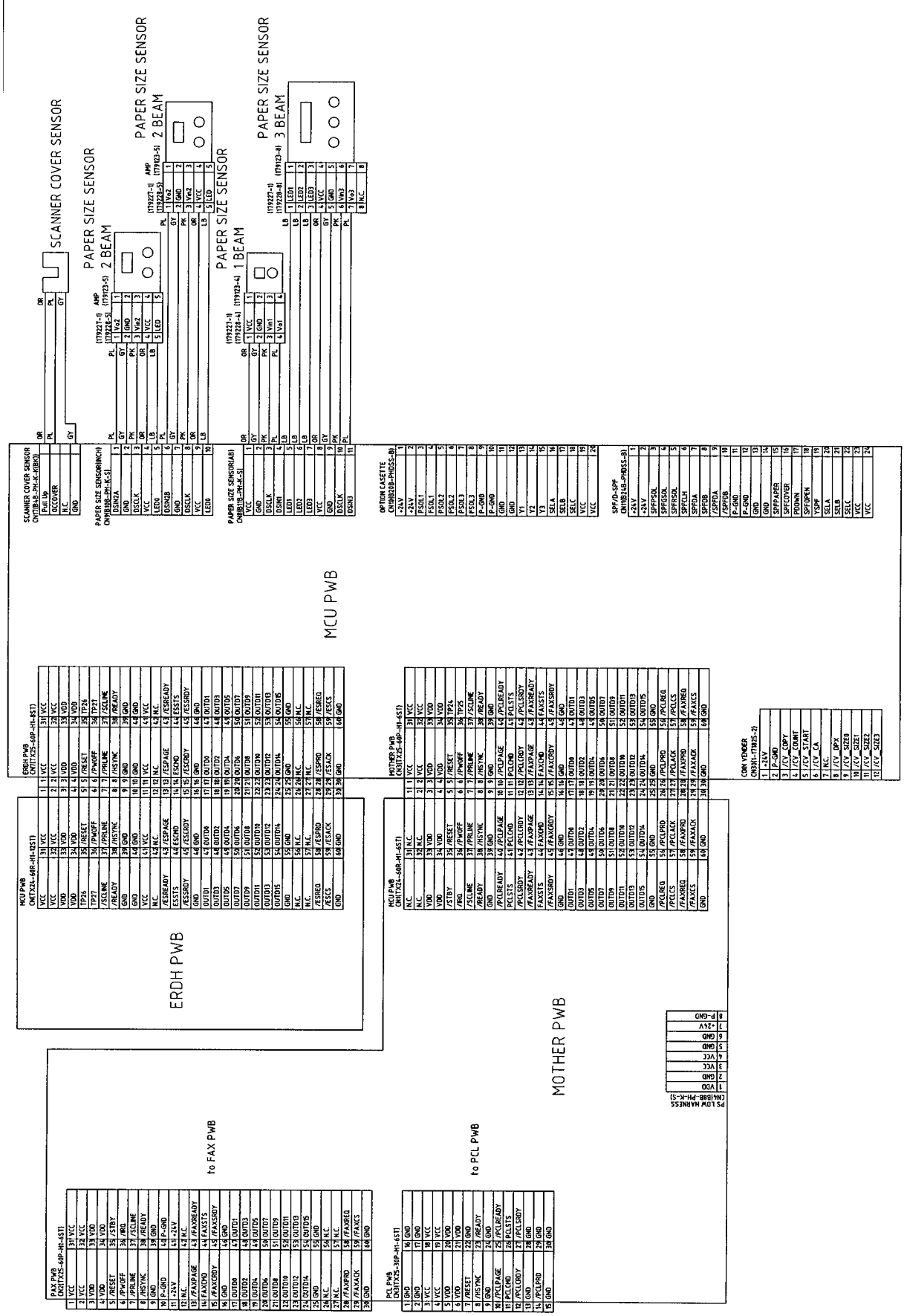

CAUTION FOR BATTERY REPLACEMENT

(Danish) ADVARSEL !
Lithiumbatteri – Eksplosionsfare ved fejlagtig håndtering.
Udskiftning må kun ske med batteri
af samme fabrikat og type.
Levér det brugte batteri tilbage til leverandoren.

(English) Caution !
Danger of explosion if battery is incorrectly replaced.
Replace only with the same or equivalent type
recommended by the manufacturer.
Dispose of used batteries according to manufacturer's instructions.

(Finnish) VAROITUS
Paristo voi räjähtää, jos se on virheellisesti asennettu.
Vaihda paristo ainoastaan laitevalmistajan suosittelemaan
tyyppiin. Hävitä käytetty paristo valmistajan ohjeiden
mukaisesti.

(French) ATTENTION
Il y a danger d'explosion s' il y a remplacement incorrect
de la batterie. Remplacer uniquement avec une batterie du
même type ou d'un type équivalent recommandé par
le constructeur.
Mettre au rebut les batteries usagées conformément aux
instructions du fabricant.

(Swedish) VARNING
Explosionsfara vid felaktigt batteribyte.
Använd samma batterityp eller en ekvivalent
typ som rekommenderas av apparattillverkaren.
Kassera använt batteri enligt fabrikantens
instruktion.

(German) Achtung
Explosionsgefahr bei Verwendung inkorrekt er Batterien.
Als Ersatzbatterien dürfen nur Batterien vom gleichen Typ oder
vom Hersteller empfohlene Batterien verwendet werden.
Entsorgung der gebrauchten Batterien nur nach den vom
Hersteller angegebenen Anweisungen.

SHARP

COPYRIGHT © 2000 BY SHARP CORPORATION

All rights reserved.

Printed in Japan.

No part of this publication may be reproduced,
stored in a retrieval system, or transmitted,
in any form or by any means,
electronic, mechanical, photocopying, recording, or otherwise,
without prior written permission of the publisher.

Trademark acknowledgments

Windows and Windows NT are trademarks of Microsoft Corporation in the U.S.A. and other countries.

IBM and PC/AT are trademarks of International Business Machines Corporation.

PCL is a trademark of Hewlett-Packard Company.

Pentium is a registered trademark of Intel Corporation.

All other trademarks and copyrights are the property of their respective owners.

SHARP CORPORATION
Digital Document System Group
Quality & Reliability Control Center
Yamatokoriyama, Nara 639-1186, Japan

2000 November Printed in Japan (N)